

# *Teo Lehtimäki Oy*

**Norge**

*2013-2014*

Uppdaterad 02.10.2013  
Foto: Janne Misikangas



**Teo Lehtimäki Oy er ett finsk familjefirma, som ble grunnlagt 1991. Vi selger reservedeler til sneskootere, og vi eksporterer våre produkter til firmaer i Scandinavia, Alpeområde i Europa, Estland og Russland.**

Vi selger kvalitetsprodukter som er produsert i Finland, og vi formidler reservedeler fra kjente produsenter, som Camoplast, CVTech-IBC Canada, PPD Industries, Garland og Wössner

Vi designer og utvikler egne produkter, eks. den populære brede skiplast "Vuotsolainen" og forlengningsatser som passer til alle skotermerker...

Firmaets virksomhet bygger på fleksibilitet, og raske leveranser.

Vi har lang erfaring, og har reservedeler inne på lager for modeller langt tilbake i tiden. Helt til da de første sneskootere ble levert. På disse sider kan du finne både tekniske råd, monteringsanvisninger, og anvendelses område for ulike reservedeler.

Disse sider oppdateres kontinuerlig, så det lønner seg å besøke sidene nå da.

# Katalog 2013-2014

Uppge alltid tydliga referensnummer. Originalnummer är angivna som referens och avser således ej originaldelar.

## Teo Lehtimäki Oy

Kaarronnevantie 54 61800 Kauhajoki Finland

Vesa Peltonen

mob. +358-40-5769111 Vesa Peltonen

fax +358-6-2311170

info@teolehtimaki.fi

vat. FI08350750

## Teo Lehtimäki Oy

Vuopajantie 34 96400 Rovaniemi Finland

Artturi Lehtimäki

mob. +358-400-162110 Artturi Lehtimäki

fax +358-16-366004

### Personliga e-mail adresser

vesa@teolehtimaki.fi Vesa Peltonen

artturi@teolehtimaki.fi Artturi Lehtimäki

### Ekonomi

Vesa Peltonen

vesa@teolehtimaki.fi

[www.teolehtimaki.fi](http://www.teolehtimaki.fi)

## Innehållsförteckning

## säsongsnyheter

- 4 - 6 No Slip, kuggjul, boggiehjul
- 7 Kullager
- 8 - 9 Glidskenor
- 10 Axlar, variatoraxlar, **dragkrok**
- 11 Växellåda, Syncro
- 12 Boggiefjädrar
- 13 Bränslepumpar, rep.satser, vindruta
- 14-16 Breda belag, **Blade, SLP skida**
- 17-22 Styrskenor, Coromant
- 23 Sekundärvariator
- 24-29 **P80, P50, ALT** variatorer och delar, ATV
- 30 Silent och **Hyvo** kedjor, kuggjul
- 31-35 Ramlager, web, packboxar, nållager
- 36-39 **Vevaxlar, renoverade**
- 40-42 **Vevstake**, nållager, packboxar
- 43-49 **Wössner smidda kolvar, snöskoter**
- 50-51 Nicasil renoverade originalcylindrar
- 52 **Seadoo / Wössner, vevaxellager**
- 53 Förgasargummi
- 54-60 Kolvar, kolvbultar, made in Taiwan
- 61 **Startmotorer**
- 62-63 Bromsklossar, huvstroppar
- 64-67 CDI, tändspolar, vltregulatorer
- 68-80 Camoplast drivband
- 81 Monteringsinstr. för arbetsskotrar
- 82-84 Förlängningssatser, monteringsinstr.



- 43-48 Snöskoter kolvar
- 49 **Sea-doo kolvar**



- 36-39 renoverade **vevaxlar**

**OBS!**

**Denna sida och 2000 andra liknande om alla  
fabrikat finns på vår hemsida.**

[www.teolehtimaki.fi/varaosaluettelot](http://www.teolehtimaki.fi/varaosaluettelot)

**Malli: MXZ 583**

**Vuosi:**

**1996**

**Moottori**

**Rotax 582, 583 1989-99**

09-772	mäntä, std
09-772-01	mäntä, 0,25 ylikoko
09-772-02	mäntä, 0,50 ylikoko
09-772-03	mäntä, 0,75 ylikoko
09-772-04	mäntä, 1,00 ylikoko
35-505	männäntäpin laakeri
710-178C	tiivistesarja, tarkista
09-55105	kampiakselin tiivisteet
09-16002	välitiiviste kampiakseli
35-6206 GPC4	kampiakselin laakeri x 3
35-6207 GPC4	kampiakselin laakeri x 2
35-6305 NRC4	kampiakselin laakeri x 1
722-2505	PTO kiertokanki
722-2505	MGT kiertokanki

**Kuva**



Omistaja: **Teo Lehtimäki**, myyty  
Ruotsiin. Tämän kelkan myyntiä  
kaduin monta vuotta  
Kuvassa **Tommi ja Lotta**

**Muut osat / Teo Lehtimäki Oy**



30-21	L=140 cm musta
30-621	L=140 cm grafiitti
30-210	L=163 cm musta

**Track Camoplast**

**38 307 / 22**

04-9793, 04-9009,  
04-9830, 04-9753

**Powerbloc / Teo Lehtimäki Oy**

**P80-kytkin 15-84 ( 1002-0009 )**



**Spring: 15-93**  
**Jousi: 15-93**  
**Shims: 9 kpl**  
**Prikat: 9 kpl**  
Pieni kartio, ei voi asentaa  
Rotax starttikehää.

**3700-3800** r/min, kytkentäkierrosluku  
**7900-8000** r/min, max. kierrosluku

**Dessa sidor  
uppdateras  
kontinuerligt**

**Vuotsolaiset Suksimuovit Ohjainkiskot  
Peltisuksi**

32-99	Suksimuovi
33-20	CTRL levike 180 mm
MM142	Kovametalli

**Muut osat / Teo Lehtimäki Oy**

05-B8	sytytystulppa
01-14342	CDI yksikkö
01-15416	tasasuuntaaja, E-mallit
01-15415	jännitteensäädin
01-14355	puola

# No Slip drivhjul, patent by Wahl Bros.

Nummer	kuggar	delning	ytter dia	axel / mm	hål
39-00	7	2,52"	136 mm	25,0-27,0	24,0 mm
39-01	7	2,52"	136 mm	27,0-29,0	26,0 mm
39-02	7	2,52"	136 mm	32,0-34,0	31,0 mm
39-05	8	2,52"	158 mm	25,0-27,0	24,0 mm
39-06	8	2,52"	158 mm	32,0-34,0	31,0 mm
39-08	8	2,52"	158 mm	27,0-29,0	26,0 mm
39-09	9	2,52"	177 mm	27,0-29,0	26,0 mm
39-10	10	2,52"	197 mm	27,0-29,0	26,0 mm
39-15	7	2,86"	155 mm	25,0-27,0	24,0 mm
39-15	7	2,86"	155 mm	32,0-34,0	31,0 mm
39-17	7	2,86"	155 mm	27,0-29,0	26,0 mm
39-18	8	2,86"	181 mm	27,0-29,0	26,0 mm
39-26	7	3,00"	163 mm	32,0-34,0	31,0 mm
39-27	7	3,00"	163 mm	27,0-29,0	26,0 mm
39-28	8	3,00"	190 mm	27,0-29,0	26,0 mm
39-38	8	2,86"	181 mm	rör axel	Polaris
39-39	9	2,52"	177 mm	rör axel	Polaris
39-42	7	2,86"	155 mm	rör axel	Ski-doo, Lynx
39-43	8	3,00"	190 mm	rör axel	Ski-doo, Lynx
21-08PO	8	3,00"	190 mm	rör axel	Polaris



## Kuggjul



Nummer	Kuggar	Delning	Diameter	Axel / mm	Sexkant
21-07K	7	2,52"	136 mm	25,0-27,0	24,0 mm
21-08AC	8	2,52"	158 mm	25,0-28,0	24,0 mm
21-08LY	8	2,52"	158 mm	32,0-34,0	31,0 mm
21-09PO	9	2,52"	177 mm	25,0-28,0	24,0 mm
21-09LY	9	2,52"	177 mm	32,0-34,0	31,0 mm

# Kugghjul

Nummer	Kuggar	Delning	Kullager	Obs!
20-5285	9	50 mm	35-6205	Ockelbo, bredd 25 mm
20-5286	9	50 mm	35-6205	Ockelbo, Trapper, bredd 30
20-5287	11	50 mm	35-6205	Lynx, Nordik 300
20-5288	10	50 mm	35-6205	Nordik PSS, 540, 550
20-5289	9	2,52"	35-6205	matta 9806, 9925, 9005
37-00	9	50 mm	-	Kugghjul, bredd 22 mm
37-01	9	50 mm	-	Kugghjul, bredd 30 mm
37-03	11	50 mm	-	Kugghjul, bredd 30 mm
37-04	11	50 mm	hexa 27mm	Kugghjul, bredd 30 mm
37-06	-	-	-	För hjul boggi 127 mm



37-06



20-5287



20-5289



20-5285



37-03



37-04

## Viktiga noteringar om vevaxelmontering

### Viktigt:

Vid vevaxelmontering hänvisas alltid till tillverkarens verkstadshandbok .

Innan vehusets bultar dras åt, kontrollera att vevaxeln, dess kullager och vevaxeltätningar passats in korrekt i vevhuset .

Innan och efter åtdragning av vevhusets bultförband, kontrollera att vevaxeln lätt kan roteras.

Följ alltid verkstadshandbokens instruktioner beträffande kullagrens infettning/smörjning.

Kullagrens livslängd beror helt på om de smorts på rätt sätt med rätt typ av smörjmedel

### Inkörning:

Det finns ingenting viktigare för att få optimal livslängd i en motor än rätt typ av inkörning. Belasta aldrig motorn maximalt under de 10 första timmarna. Kör lungt med varierat gaspådrag. Utsätt aldrig motorn för långa fullgaskörningar och/eller hög belastning. Avbryt körningen om onormalt ljud eller vibrationer uppstår. Analysera och åtgärda orsaken innan körningen fortsätter

### Garanti:

Renoverade standardkomponenter har en garanti om ett år med början från fakturans datum. Komponenterna skall vara monterade av fackkunig och utbildad personal.

## VIKTIG NOTERING

### Vevaxelmonteringsinstruktion

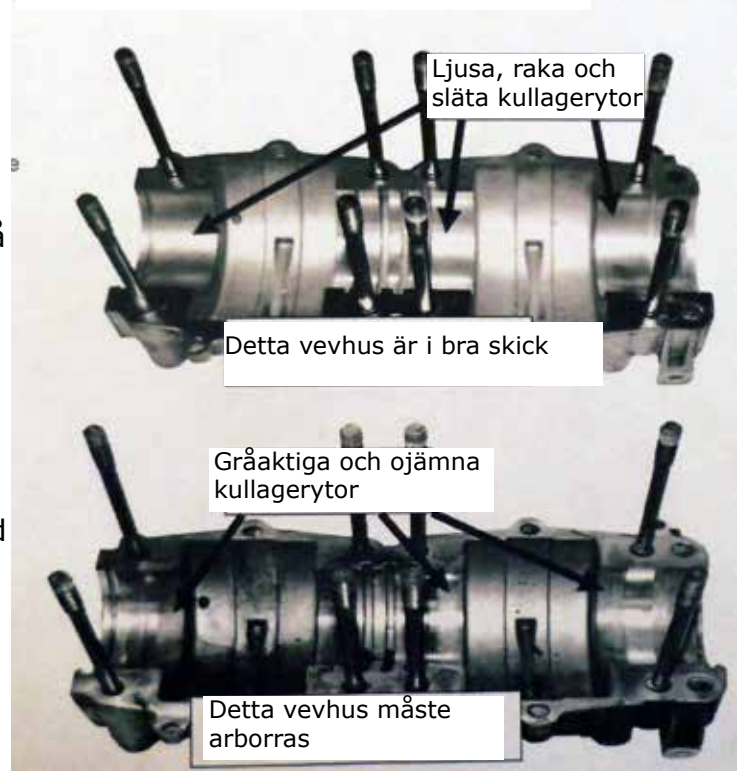

# Boggiehjul



Nummer	Dia	Lager	Färg	passar:
20-82	082	35-620258	svart	alla med 82 mm hjul
20-108	108	35-620258	svart	Ski-doo, Lynx, Polaris
20-127	127	35-620258	svart	Lynx
20-130	130	35-6004	svart	Yamaha
20-133	133	35-6004	svart	Lynx, Ockelbo
20-135	135	35-6205	silver	Ski-doo, Trapper, Nordik
20-135F	135	35-6205	silver	Full moon, Ski-doo, Lynx
20-135P	135	35-6304	silver	Full moon, Ski-doo, Lynx
20-5350	135	35-6205	silver	Polaris, insatshylsor
20-5630	143	35-6205	svart	Arctic Cat
20-5630H	143	35-6205	silver	Arctic Cat
20-5630G	143	35-6205	grön	Arctic Cat
20-155	155	35-6205	svart	Ski-doo, Trapper, Nordik
20-6380H	160	35-6205	silver	Polaris, Arctic Cat
20-6375S	160	35-6205	blå	Polaris, Arctic Cat
20-165K	165	35-6205	gul	Lynx
20-165P	165	35-6205	röd	Lynx
20-165H	165	35-6205	silver	Lynx
20-180	180	35-6205	silver	Lynx, 04-3000 flippen
20-131	180	35-6204	svart	Yamaha
20-200	200	35-6205	svart	alla

## Boggi fronthjulsats

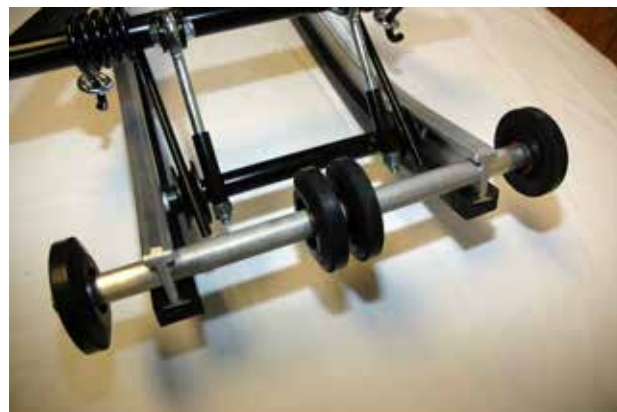

Stab hjulsats bidrar till att förhindra skador på mattan genom att eliminera risken för att boggiskenornas spetsar kommer i kontakt med mattan

39-791 Center, 223 mm axel  
Arctic Cat, Yamaha  
39-793 Center, 220 mm axel  
Skidoo, Polaris, Lynx

# Kullager

Nummer	hål	o dia	bredd
35-6201	12	32	10
35-6202	15	35	11
35-620258	15,875	35	11
35-6203	17	40	12
35-6204N	20	47	14
35-6205N	25	52	15
35-6303	17	47	14
35-6304	20	52	15



Nummer	hål	o dia	bredd
35-CB205	25	52	15
35-SC205T	25,4	52	15



Nummer	hål	o dia	bredd
35-UC205	25	52	17
35-UC205T	25,4	52	17



Nummer	hål	o dia	bredd
35-30303			
35-3205	25	52	21



Nummer	hål	o dia	bredd
35-6004	20	42	12
35-6005	25	47	12
35-6006	30	55	12
35-6008	40	68	15
35-6010	50	80	16
35-6022	22	44	12
35-6228	28	58	16

Nummer	hål	o dia	bredd
35-SA205T	25,4	52	15



Nummer	hål	o dia	bredd
35-SB205	25	52	15
35-SB205T	25,4	52	15



Nummer	hål	o dia	bredd
35-RB205	25	52	15
35-AS205	25	52	15



# Kulled

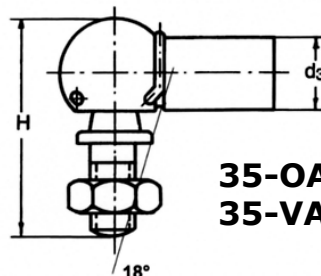

35-OAS16 M10 höger  
35-VAS16 M10 vänster

# Glidskenor

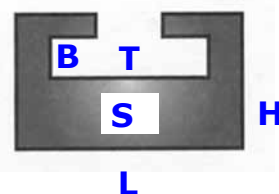
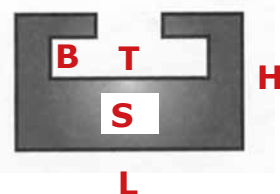

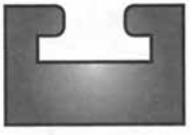
Arctic Cat	Bredd L mm		Höjd H		Tjocklek S	B ,mm	T ,mm
	<b>30</b>		<b>20</b>		<b>9,5</b>	<b>5</b>	<b>19</b>
	Nummer	Längd cm	Färg	Arctic Cat, alla modeller efter -78			
	<b>30-10</b>	140	svart				
	<b>30-610</b>	140	grafit				
	<b>30-167</b>	167	svart	Arctic Cat, Super Jag, Karibo			

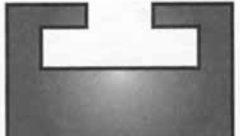
Ski-doo, Lynx	Bredd L mm		Höjd H		Tjocklek S	B ,mm	T ,mm
	<b>37,5</b>		<b>19</b>		<b>10</b>	<b>5</b>	<b>26</b>
	Nummer	Längd cm	Färg	Lynx, alla fram till G-type, efter det arbetsskotrar			
	<b>30-01</b>	140	svart				
	<b>30-601</b>	140	grafit				
	<b>30-010</b>	163	svart	Skidoo gamla mod., till -96			
<b>Trapper, Nordik</b>	Trapper, Nordik-300,500,600						

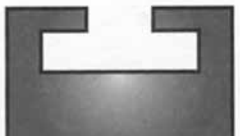
Ski-doo Nordik	Bredd L mm		Höjd H		Tjocklek S	B ,mm	T ,mm
	<b>37</b>		<b>20</b>		<b>10</b>	<b>7</b>	<b>24,5</b>
	Nummer	Längd cm	Färg	Nordik 377 R, 540, 550			
	<b>30-00</b>	155	vit.				

Ski-doo, Lynx	Bredd L mm		Höjd H		Tjocklek S	B ,mm	T ,mm
	<b>38</b>		<b>17</b>		<b>9,5</b>	<b>4,5</b>	<b>22</b>
	Nummer	Längd cm	Färg	Lynx G-type från och med			
	<b>30-21</b>	140	svart	Skidoo REV, RT & RF, SC4 boggie			
	<b>30-621</b>	140	grafit				
	<b>30-210</b>	163	svart				
<b>30-321</b>	140	gul.					

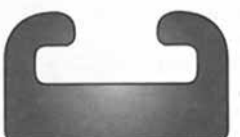
Ski-doo, Lynx	Bredd L mm		Höjd H		Tjocklek S	B ,mm	T ,mm
	<b>38</b>		<b>15</b>		<b>7</b>	<b>5</b>	<b>27</b>
	Nummer	Längd cm	Färg	Formulat, GT mod., Mach1, Z, MXZ,			
	<b>30-260</b>	140	svart	Legend, MX Rev, Summit, Renegade			
	<b>30-270</b>	151	grafit				
	<b>30-280</b>	163	svart				
	<b>30-360</b>	140	gul.				
Lynx 2009- RS 600, SC 4 boggie,							

# Glidskenor

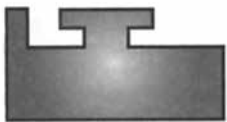
<b>Polaris</b>	Bredd L / L mm		Höjd H		Tjocklek S	B ,mm	T ,mm
	<b>31</b>	<b>37</b>			<b>11</b>		
	Nummer	Längd cm	Färg				
	<b>30-15</b>	140	svart	Alla mod. t.o.m 2000,			
	<b>30-615</b>	140	grafit	XTRA 10, XTRA 12 smal profil			
<b>30-150</b>	145	svart					
<b>Obs: mått</b>	<b>30-618</b>	140	grafit	Polaris- Storm, XCR, bred profil			

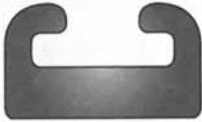
<b>Polaris</b>	Bredd L mm		Höjd H / H		Tjkl. S / S	B / B	T / T
	<b>32</b>		<b>19,5</b>	<b>22,0</b>	<b>9 / 11</b>	<b>5 / 6</b>	<b>22 / 23</b>
	Nummer	Längd cm	Färg	Edgr RMK 03-05, Edge 2000-05,			
	<b>30-23</b>	140	svart	340 mod. -99-05, Lite 97-98			
	<b>30-623</b>	140	grafit	Indy Sport -97-99,			
<b>30-230</b>	167	svart	2000-				
<b>Obs: mått</b>	<b>30-240</b>	163	svart	gen II RMK, XC, M-10 , Indy Edge			

<b>Yamaha</b>	Bredd L mm		Höjd H		Tjocklek S	B ,mm	T ,mm
	<b>30</b>				<b>7</b>		
	Nummer	Längd cm	Färg	Phaser, Ovation, SRV, SS			
	<b>30-12</b>	140	svart				
	<b>30-612</b>	140	grafit				

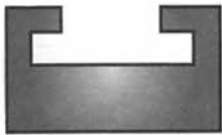
<b>Yamaha</b>	Bredd L mm		Höjd H		Tjocklek S	B ,mm	T ,mm
	<b>30</b>		<b>15</b>		<b>7</b>	<b>5</b>	<b>24</b>
	Nummer	Längd cm	Färg				
	<b>30-16</b>	140	svart	Viking, Exciter 87-90, Phaser 90-99			
	<b>30-616</b>	140	grafit.	V-max 92-97,			
			V-max 500-600 94-96				

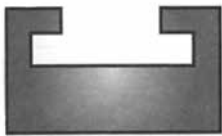
<b>Yamaha</b>	Bredd L mm		Höjd H		Tjocklek S	B ,mm	T ,mm
	<b>30</b>		<b>18</b>		<b>10</b>	<b>5</b>	<b>24</b>
	Nummer	Längd cm	Färg				
	<b>30-20</b>	140	svart.	V-max 97-03,			
	<b>30-200</b>	145	svart	Mountain max 97-02			
<b>30-620</b>	140	grafit	SX, SRX, SXR, 98-04				

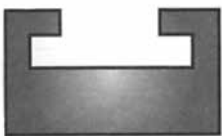
<b>Yamaha</b>	Bredd L mm		Höjd H		Tjocklek S	B ,mm	T ,mm
	<b>34</b>		<b>18</b>		<b>10</b>	<b>5</b>	<b>25</b>
	Nummer	Längd cm	Färg				
	<b>30-625</b>	145	grafit	RX1 mod. 2005- RS mod. 2005-			
	<b>30-635</b>	157	grafit				
			Apex, Attack 2006-				
			Nytro 2006-				



# Drivaxel 5900

## 11-59 Drivaxel 5900

Passar på 1989-1995 modeller



## Boggie axel

11-08	5492814	bakaxel	Lynx 250
11-09	5493615	bakaxel	Lynx 5900
11-10	5496216	bakaxel	Lynx 360, 3900
11-11	05032390	bakaxel	Nordik 500, 540
11-12	05032389	bakaxel	Nordik 300, 377R
20-5289		Jos Lynxissä on takana hammaspyörät, 9 tai 11 hampaiset ja reikävetoinen matto: Ainoa helppo tapa vaihtaa uusi matto on asentaa taakse oheiset 20-5289 pyörät. Ne on tehty sisävetoisen maton 2,52" jaolle. Lisäksi 50 cm leveään mattoon tarvitaan tukipyörä	
11-60	förlängning	att förlänga flippens armar	
<b>Variatoraxel</b>			
11-20	5394111		Lynx 250S, 3900S
11-21	5398073		Lynx 360S, Ranger
11-22	539990		Fox -99
11-23	5146138		Fox 00-
11-25	875138073		Syncro hylsan



## Dragkrok



12-01 Universal



12-02 Skidoo



12-05  
Ny, Lynx



12-04 Skidoo  
12-04XP Skidoo -09-



# Växellåda och Syncro



## Nyheter

### 43-27

Kugghjul **8751-46293**  
27 kuggar v. 1989-1997  
Lynx 5900, 3900, 6900



### 43-68 600cc L/C vätskekyld vm.2002-05

Nedre	<b>Z=53</b>	<b>8751-56114</b>
Mellan	<b>Z=31</b>	<b>8751-56156</b>
Övre	<b>Z=28</b>	<b>8751-56206</b>



### 43-32

Kugghjul **8751-46042**  
32 kuggar  
v. 1989-1996  
Lynx 5900, 3900, 6900

## Syncro drevsats

### 43-65

**1992 fr.m**

nedre, bred	z=64	8751-55048
mellan, vänster	z=33	8751-47643
mellan, höger	z=33	8751-47644

### 43-64

**till 1992**

nedre, bred	z=64	8751-55048
mellan, vänster	z=31	8751-47202
mellan, höger	z=31	8751-47203





## Sisu växellåda, drev

### 43-66

**1996-2003**

nedre	Z=55	8751-56048
mellan	Z=31	8751-56049
nedre	Z=28	8751-56050

<b>41-3000, 9mm</b>	<b>41-3281, 8 mm</b>
	Lynx 250, 3900
	Lynx 5900

<b>41-8797, 10 mm</b>	<b>41-8796, 9 mm</b>
	Ranger, 5900, ym

Ca. 20% starkare	<b>40-PZ</b>
	12 mm
	Nytro
	Phazer 07-

kortare tråd 50 mm längre än 40-PZ	<b>40-LT</b>
	Mt Lite

8-varv, 11,5 mm	<b>40-POLA</b>
	Polaris
	Skidoo
	Lynx

9-varv, 11,0 mm	<b>40-PO</b>
	Polaris 90-

Edge boggi, 11,0 mm	<b>40-EDGE</b>
	Polaris
	Skidoo
	Summit

Bakfjäder	<b>40-4716</b>
	Nordik 300
	Skidoo
	<b>40-0310,</b>
	Fram fjäder.

Främrefjäder	<b>40-CA</b>
	Karibo
	Arctic Cat

Som	
40-POLA	<b>40-AC, 11,5 mm</b>
	AC, de nyaste
	<b>40-VI, 12,0 mm</b>
	Yamaha Viking

	<b>41-1530, 9 mm</b>
	Lynx 5900
	med ring
	<b>40-4715, 8,5 mm</b>
	Nordik 500-600

Bakfjäder	<b>41-8805</b>
	Ranger
	Lynx 5900

Bakfjäder	<b>41-4175</b>
	Lynx 3900

Bakfjäder	<b>41-4277</b>
	Lynx 5900
	10,0 mm

Bakfjäder	<b>41-4500</b>
	Lynx 5900
	9,0 mm

Bakfjäder	<b>40-4721</b>
	Nordik 540
	Trapper
	<b>41-1531</b>
	Lynx 5900

Med krok 11,5 mm	<b>40-POL</b>
	Polaris
	ända t.-89

Fjädrarna på bilderna är högerlindade

# Vindrutor

Obs: mät alltid rutans höjd i mitten !!!

00-110	5393062	00-140	5393890-1
	GL 250 - >88		Lynx 640
00-111	524090X	00-141	6500202-2
	GL 250 S, GL 230 89->91		Lynx 650 skruv. 1995
00-112	526754	00-142	533084X
	GL 360 S 92->95		Lynx 650 met. 83->94
00-115	539504	00-151	537644
	Forest Fox 96->98, 01		RANGER, LIGHT, GT 93->97
00-120	522842X	00-181	5241686
	GL 3900, GLX 5900 låg->93		GLX 5900 96->99, 6900 1997
00-121	538284-1	00-300	Nordik 300
	GLX 5900, skruv. 1995		
00-122	523192X	00-377	Nordik 377 R
	GLS 3300 låg		
00-123	538616	00-500	Nordik 500, 600, 7 laxfena
	GLX 5900, laxfena 1995		
00-130	524126X	00-510	Trapper, 5000, 5 laxfena
	GL 3300, GL 3900 S, 88->92		
00-535	Lynx 535	00-550	Nordik 550, 540
	Lynx 535, alla		

## Bränslepump



31 l.

08-188



70 l.

08-200



08-187



Primer



03-7000, ej slang  
03-7000A, slang

## Reparationssats MIKUNI

08-103 Mikuni ( 07-187-05 )

08-104 Mikuni ( 07-187-11 )

Filter, i Startklacksatser Rotax  
bränsletank



03-7311



01-154

## Startfjäder

- |         |            |                 |
|---------|------------|-----------------|
| 01-1560 | Rotax      | 414 783 400     |
| 01-158  | Rotax      | 420 939 115     |
| 01-2080 | Arctic Cat | 3001-077        |
|         | Polaris    | 308-3185        |
|         | Yamaha     | 8YO-15713-00-00 |
| 01-207  | Kohler     |                 |



## Gasvajerförlängning kit ca.20 cm 03-5000



## Extra breda belag

## Vuotsolainen

Delnummer	Bredd	Obs	Passar på m.fl.
	mm		
31-00	250		Alpine,
31-01	250		Universal
31-02	200		Universal
31-03	225		plastskida, ADJ
31-03R/L	225		pilot skida, höger-vänster
31-04	200		pilot smal
31-05	225	med hål	Yamaha
31-09	225	med hål, Polaris	Polaris, Arctic Cat
31-10	240	med hål, <b>nyhet</b>	Lynx, Skidoo DS pilot
31-11	230	<b>med hål, nyhet</b>	Lynx, SLP, Blade skida 2013



**31-01**

**31-02**

**31-03**

**31-03R / 31-03L**



## Extra breda belag

## Vuotsolainen

31-04

31-05

31-09

31-10

31-11



## Skidbelag

## 8 mm HPDE.



32-01

Arctic Cat



32-06

Arctic Cat



32-00

Ockelbo



32-11

Trapper, Nordik



32-99

Safari, Scandic 380



32-21B Formula, Snowexpert



32-61

Lynx



32-41

Polaris 1993-



32-51

Polaris -92, Ockelbo



32-81

Yamaha Viking



32-88

Yamaha Phaser 98-



32-91

Yamaha V-max 94-



**31-01**

Vuotsalainen

## Skidbelag för plastskidor



**33-40**

**Polaris**



**33-60 Skidoo / Lynx flex**



**33-20 CTRL skida,**  
ej förborrad, passar även på andra mod.



**33-50 Pilot, smal model**



**33-10**

**Arctic Cat**



**33-80 Yamaha SRX 1998-**



**33-90 Yamaha 2000 / Skidoo / Lynx**  
ej förborrad, passar på andra mod.



**33-99 Yamaha RX-1**  
text 33-99 mellan bakre hål och  
text 33-90 YA, liten, liten text.

**31-06 Bukplast**  
**6 x 800 x 1000 mm**

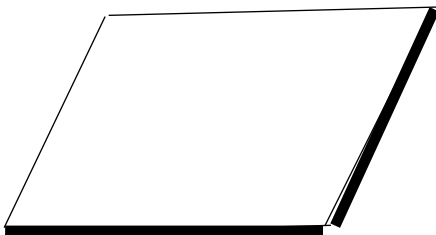

Se plastbelag på vår hemsida  
[www.teolehtimaki.fi](http://www.teolehtimaki.fi)

**31-00**

**Alpine II**

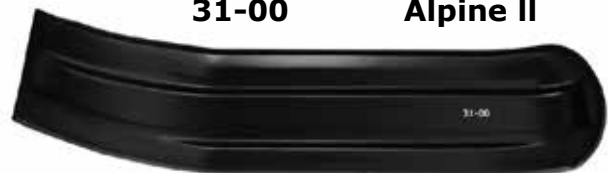

**Plastskiva**

**31-07**







**8 x 150 x 3000**





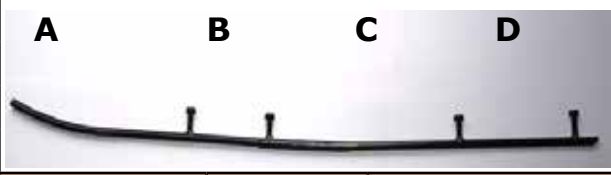

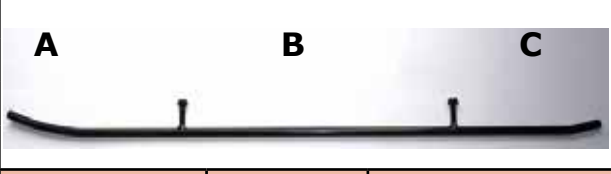
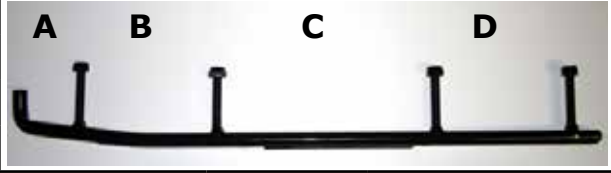
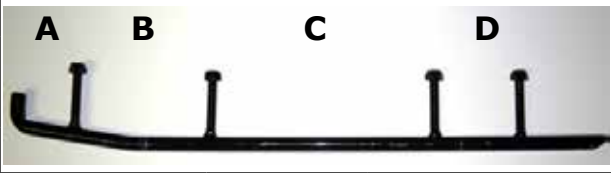
**31-08**

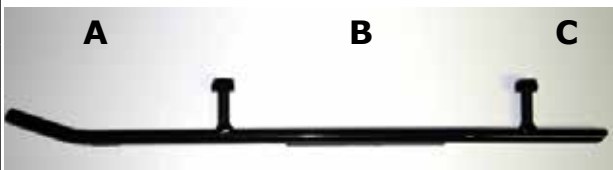
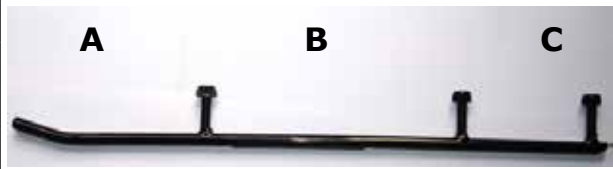
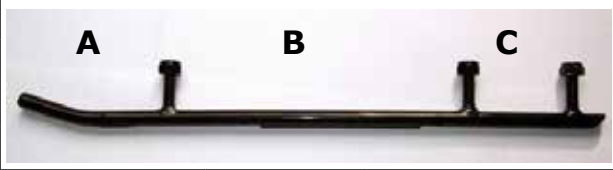

**8 x 150 x 2000**

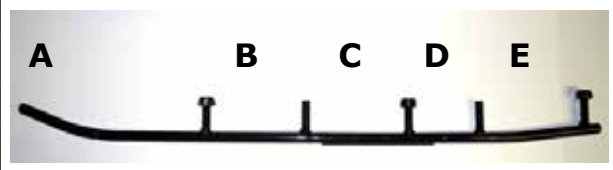
# ARCTIC CAT

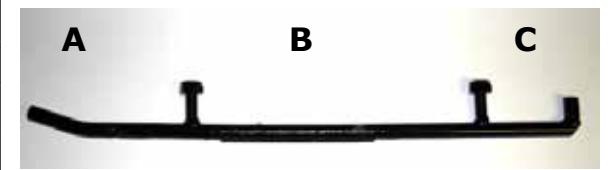
# Styrstål

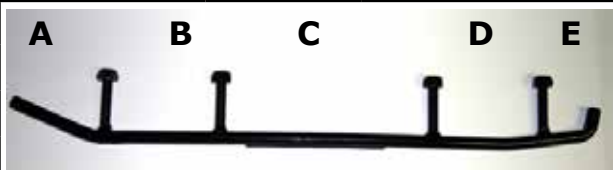

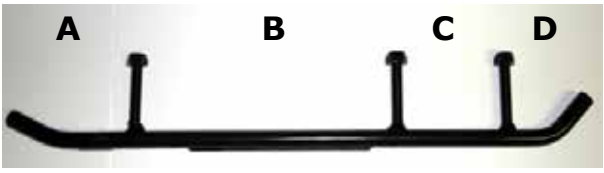

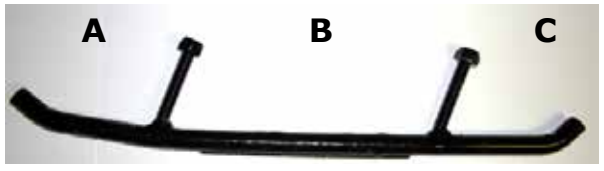
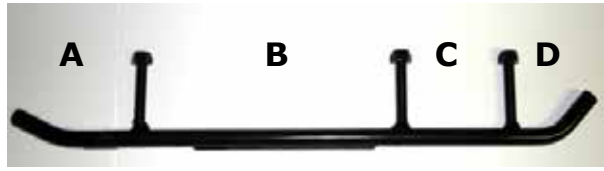
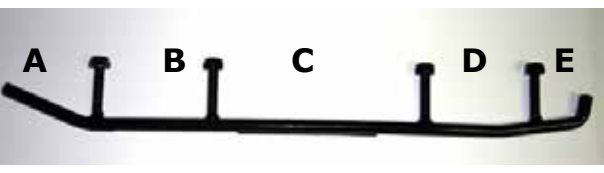
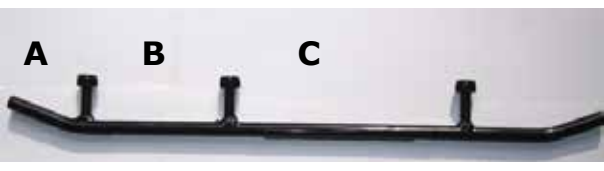
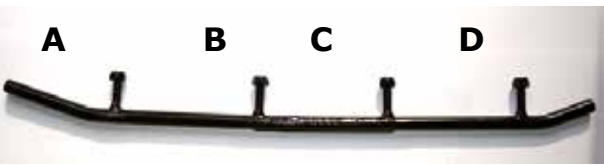
Järn	Racing	Coromant	L=Längd	A	B	C	D	E				
MM203		MM169	772	386	386	-	-	-				
			<b>AKTIV:</b> Alaska, Panther, Karibo 1984-1986, och <b>ARCTIC CAT:</b> El Tigre 1980-84, Jag 1980-91, Panther 1980-89, Super Jag 1987-92 Trail Cat 1980-81, Pantera 1980-85									
			MM205		MM170	776	343	433	-			
						Cheetah Tour 1987-91, Cougar 1987-91 El Tigre 1987-90, Jag AFS 1989-91 Manx 1991-, Pantera 1987-90 Panther 1990-91, Wild Cat 650 1988-90						
						MM260		MM133	787	260	108	249
			Ext Special 1992, Ext 580,Z 1993-94, Jag Special, Z 1992, Prowler Spec. 1992-94 Wild Cat 700 EFI 1992-94, ZR 440 1993-95 ZR 580,700 1993-95, Thunder Cat 1996									
			MM210		MM173	610	356	127	114			
						Bear Cat 340,440 1995-99, Cheetah Tour 1992-94 Cougar 1992-97, Ext, EFI 1992-93, Manx 1992-93 Jag AFS DL 1992-93, Prowler 2-UP 1992-94 Pantera 1992-97, Panther 1992-93, Prowler 1991-96 Thunder Cat 1993-95						
						MM261			791	236	380	193
			El Tigre 1985-86 Cougar 1985-86 Cheetah 1986 Pantera 1986									
			MM262		MM157	469	57	114	178	114		
						Plastskidor 1996-						
						MM263		MM158	469	57	114	178
			Plastskidor 2005-???									
			<b>SLP skida</b>			<b>Blade skida</b>						
MM290	MM390	MM190	470	89	179	90	112					
			SLP skida									
			Styrstålen visas alltid med <b>främre delen mot vänster</b>									

Järn	Racing	Coromant	L=längd	A	B	C	D	E	
<b>MM242</b>		<b>MM189</b>	<b>470</b>	<b>170</b>	<b>235</b>	<b>65</b>			
			Forest Fox 1999-, GL360, 250 1991-93, GL 2300 -90 GL 3300 1989-90, GL 3900, LTS 1991-92 GLS 3900 1989-90, GLX 5900, LTS 1991-93 GL Sport, LTS 1991-92, Ranger 1993						
<b>MM230</b>		<b>MM187</b>	<b>550</b>		<b>235</b>				
			GL 250. 250S 1986-89, GL 3900 1983-88 GL 5900 1983-90 535, 650 1983-87 640 1988						
<b>MM240</b>		<b>MM188</b>	<b>450</b>		<b>228</b>	<b>81</b>			
			GLS 3300 1986-89, GLS 3500 F/C 1990-93 GLS 3600 L/C 1990-91, Cobra 1992-93 3800 Rave, Ultra, Cobra Touring, Rave , Cobra Racing, Enduro 1993						
<b>MM241</b>			<b>450</b>		<b>219</b>				
			230, 250, 650 1989-93						
<b>MM265</b>		<b>MM154</b>	<b>660</b>	<b>215</b>	<b>110</b>	<b>114</b>	<b>80</b>	<b>122</b>	
			G-type Rave 1997-99 Enduro 600						
		<b>MM153</b>	<b>530</b>	<b>120</b>		<b>115</b>	<b>110</b>	<b>80</b>	
			G-type Racing 1998- Sport XR 98						
		<b>MM152</b>	<b>440</b>	<b>130</b>	<b>228</b>	<b>77</b>			
			G-type 1997-99 Enduro 500						
<b>MM250</b>		<b>MM193</b>	<b>625</b>	<b>321</b>	<b>241</b>	<b>63</b>			
			Ranger kort stålskida av Skidoo 2000-						
<b>MM279</b>		<b>MM146</b>	<b>537</b>	<b>90</b>	<b>103</b>	<b>190</b>	<b>103</b>	<b>54</b>	
			<b>FLEX</b> plast 2000- Samma skida, Skidoo						

Järn	Racing	Coromant	L=Längd	A	B	C	D	E	
MM277		MM147	400	87	177	75	60		
			Plastskida, <b>Camoplast</b> skida 2003- Också Skidoo och Polaris						
MM243	MM386	MM186	520	210	192	121			
			ADJ skida, <b>CTRL</b> skida 2003-						
MM255			520		192				
			ADJ med tre bultar						
<b>SKI-DOO</b>									
MM274		MM144	335	89	160				
			Pilotti skida/ Skidoo, smal och bred						
MM277		MM147	400	87	177	75	60		
			Plastskida, <b>Camoplast</b> 2003- Också Lynx och Polaris Skandic 380-550 2003-						
MM279		MM146	534	84	103	190	103	54	
			Plastskida FLEX 1997- Också Lynx						
		MM141	445	54	95	222			
			Formula 583 1998 Formula III 600, 700 1997-99 Formula Mach I, Z 1997-99, Formula Z 1997-99 G-Touring 583, 670 1997-99, Summit 1997-99						
		MM142	502	90	126	110	116	60	
			MXZ 440, 583, 670 1996-99						

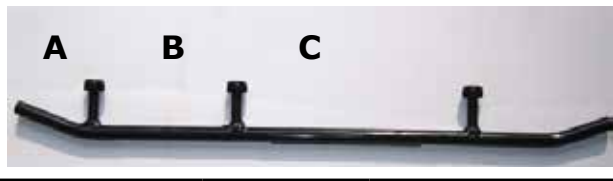
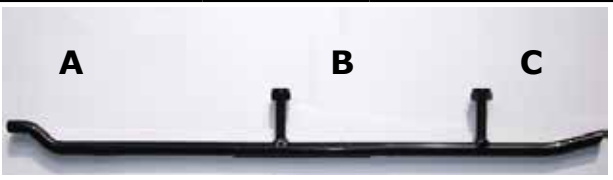
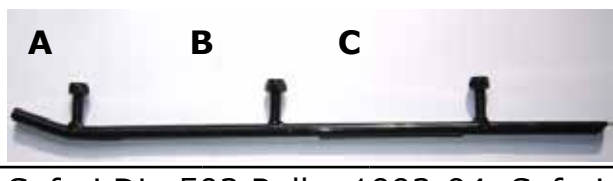
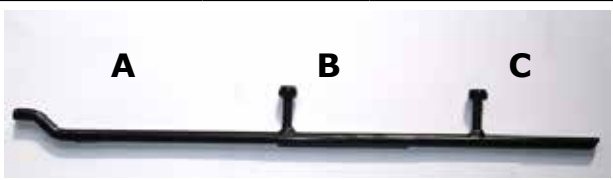
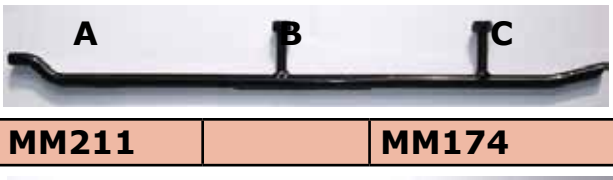
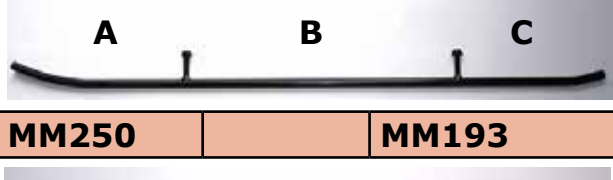

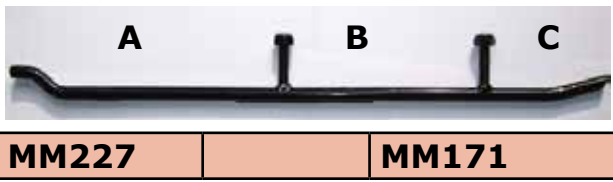



# SKI-DOO



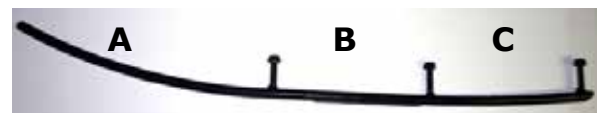
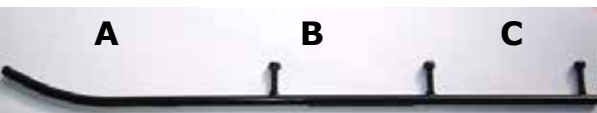
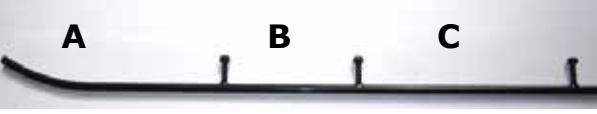

# Styrstål

Järn	Racing	Coromant	L=Längd	A	B	C	D	E	
		<b>MM143</b>	<b>495</b>	<b>54</b>	<b>120</b>	<b>196</b>	<b>115</b>		
			Formula III 1985-96, Formula Mach Z 1985-96 Formula MXZ 1993-95, Formula Z 1994-96 G-Touring 583, 670 1993-96 Summit 1994-96						
<b>MM229</b>			<b>602</b>	<b>248</b>	<b>176</b>				
			Formula SP DL 1985-86, Tundra 1985-97 Safari 377, 447, 503 1984-88 Safari, Saga, Scout 1989-92 Skandic 377, 503 1986-87						
<b>MM216</b>		<b>MM163</b>	<b>602</b>		<b>170</b>	<b>170</b>	<b>99</b>		
			Formula Mach I 1989-94, Formula SS 1995-96 Formula MX, XTC 1985-95 Formula Plus, XTC 1985-93 Formula ST, STX 1994-96, Grand Touring 470 -95 Safari DL, 503 Rally 1993-94, Safari GLX, LCE, L 1990-94, Skandic II 377, 503 92-94						
<b>MM275</b>		<b>MM145</b>	<b>545</b>		<b>178</b>	<b>114</b>			
			Blizzard 1978-84, Nordik 1981-83 Everest 1974-83, Olympique 1976-79 Skandic 277, 377 1982-85 TNT 1973-78						
<b>MM215</b>		<b>MM176</b>	<b>527</b>	<b>238</b>	<b>177</b>	<b>112</b>			
			Safari Cheyenne 1989-91 Alpine II 1991-95						
<b>MM211</b>		<b>MM174</b>	<b>483</b>	<b>162</b>	<b>178</b>				
			Citation 1980-91 Elan 1971						
<b>MM250</b>		<b>MM193</b>	<b>625</b>	<b>321</b>	<b>241</b>	<b>63</b>			
			Formula 500, DL 1996-99 Formula 583 1996-99, Formula S, SL, SLS 95-99 G-Touring 500 1996, Scandic 380, 500 1995-						
<b>TRAPPER, NORDIK</b>									
<b>MM215</b>		<b>MM176</b>	<b>527</b>	<b>238</b>	<b>177</b>	<b>112</b>			
			Nordik 300-377 Nordik 500-600 Nordik 540-600 SL						
<b>MM227</b>		<b>MM171</b>	<b>480</b>	<b>250</b>	<b>148</b>	<b>82</b>			
			Nordik 500 PSS, Nordik 550						

# POLARIS

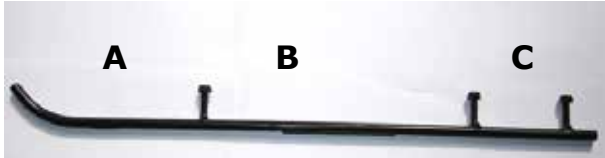
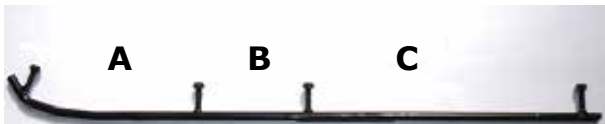
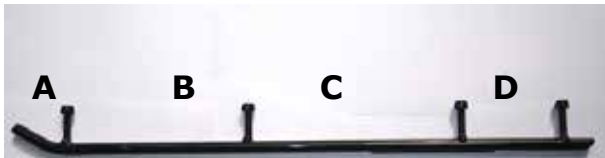
# Styrstål

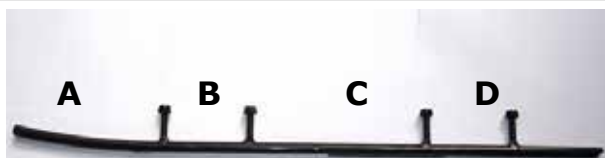
Järn	Racing	Coromant	L=Längd	A	B	C	D	E	
MM202	MM348	MM148	722	180	160	178	178		
			<b>Plastskida 2007-</b> <b>Ersätter originalen</b> <b>MM348 racing styrstål</b>						
MM270		MM149	680	310	178	178			
			<b>Plastskida 1997-</b> Indy RMK 700, Indy XC 400, Indy XCR 600 1997- Indy Storm, Indy Ultra 1997-						
MM206		MM159	673	317	178	178			
			Alla modeller/All mod. 1988-98 Alla med stålskida/ 1998-99 Indy Sport 1987						
MM209		MM177	813	317	178	255			
			Indy 400, 600, Trail, Longtrack, Sprint SS, Star, Startrack 1986-87						
MM208			813	405	408				
			Alla modeller 1971-82 Indy 600, 400, Trail, Longtrack, Sport, SS, Star, LT 1983-85						
MM328	MM398	MM198	460	60	115	180			
			<b>Polaris Gripper skida</b>						
<h2>OCKELBO</h2>									
MM207		MM160	800	395	405				
			Alla modeller -1986 <b>Ockelbo</b>						
MM228		MM162	450		270				
			Alla modeller 1987- <b>Ockelbo</b>						
<h2>YAMAHA</h2>									
MM219			578	57	184	311			
			BR 250 1982-94 ET 250, 300, 340 1977-84 SR 540 1980-84 SRX 440 1976-80						

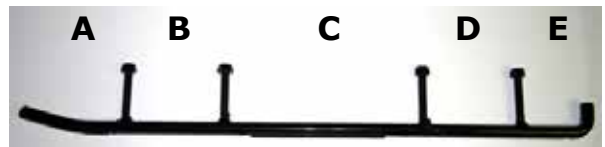
Järn	Racing	Coromant	L=Längd	A	B	C	D	E	
MM217		MM138	621	60	174	268			
			ET 340 1985-88						
MM224		MM164	635	216	292	101			
			Exiter 570 1987-90						
			SR 540, V-MAX 540 1987-91						
MM280		MM137	768		140	360			
			BR 250 T, TS 1984-98						
			ET 340 T,TR 1981-88						
			ET 400 T, TR 1989-91						
			EX 340, 440 1977-81						
MM232		MM166	663	57	183	210	101		
			CS 340 1990-99, Exiter II 570, SX 1991-93						
			Phazer II, E, ST 1984-99, SR 540 1985-86						
			V-Max 540 1983-86, Viking II 540 1988-92						
			XLV 540 1985-91						
MM235		MM175	604		181	210			
			ET 410 TR 1992-99						
			Viking II 540 E 1993-99						
			Venture 480 1991-99						
MM251		MM194	608	159	90	185	90		
			V-Max-4 1992-94						
			Venture 500,600,700 1995-96						
			V-Max 500, 600, 700 1994-96						
			V-Max 800 1995-97						
MM281		MM136	419		82	176	59	62	
			V-max 500, 600, 700 1997-99						
			Venture 500,600,700 1997-99						
MM282		MM135	475		124	160	118		
			SRX 600, 700 1998-						
MM239	MM339	MM139	530	100	90	180	90	70	
			RX, RX-1 2002-						

# Sekundärvariator

Året Year	Modell, make, modelle	Ro- tax	osa # part #	dia aks.
	Terri 30, 2020		14-6038	22,2
	Trapper, Ockelbo		14-6024	25,0
84-93	535, 5900 GLX, 650	503	14-6028	22,2
-93	GL 250	253	14-6028	22,2
-93	360, Ranger, GL3300	377	14-6028	22,2
94-96	360 S, Ranger	377	14-6041	22,2
-96	Ranger380,Fox,Light	380	finns ej	
94-96	GLX 5900FC, 650 S	503	14-6041	22,2
94-96	GLX 5900 LC	493	14-6041	22,2
97-98	Ranger 380,	380	finns ej	
97-98	Fox, S, Light Touring	380	finns ej	
97-98	GLX 5900 FC, 6900	503	14-6032	25,0
97-98	GLX 5900 LC	493	14-6032	25,0
99-03	GLX 5900 FC	503	14-6032	25,0
99-04	6900	503	14-6032	25,0
99-??	Fox 440	447	finns ej	
99-00	GLX 5900	493	14-6032	25,0
2000-	Ranger 500 FC	503	14-6032	25,0
2000-	Ranger 500 LC	493	14-6032	25,0
2001-	5900 ST	593	14-6032	25,0
2004-	SUV 550, Ranger	550	14-6032	25,0
2004-	6900	550	14-6032	25,0
2004-	SUV 600, ST 600	593	14-6033	25,0
2004-	5900 Yeti V-1000		14-6021	25,0
2005-	5900Yeti 600HO SDI	593	14-6021	25,0
2006-	SUV 600,Ranger 600	593	14-6021	25,0
2007-	TUV 600 HO SDI	593	14-6021	25,0
2007-	Yeti, Yeti Pro V-800	800	14-6021	25,0

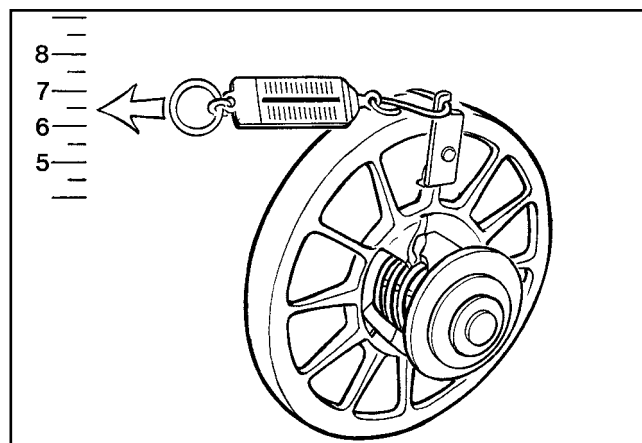

När du har monterat i en ny variator eller reparerat den gamla, kolla alltid fjädern i sekundärvariatorn. Väldigt ofta är den för svag och fungerar inte som den ska.

Den växlar upp för tidigt och växlar ner för sent vilket gör att motorn inte orkar. Därför lönar det sig att spänna den gamla fjädern eller montera dit en ny. Du bör också alltid rengöra delarna.

## Linjering

Kolla variatorernas linjering med en rak stång. Om det inte finns någon vridstopp eller begränsare i din skoter, som hindrar att motorn vrider sig under drift, så måste måttet **Y** vara minst 1,0-1,5 mm större än måttet **X**. Notera också att ny CVTech, IBC är mindre i diameter och därför är ägarhandbokens **Z** mått ej rätt.

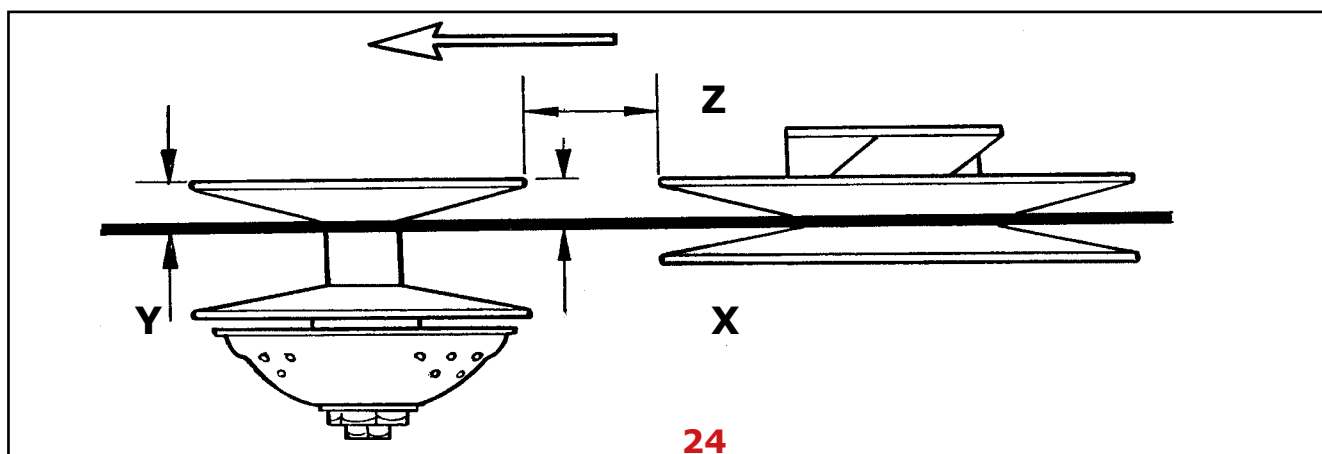

# Powerbloc 80

Servicefri variator till stora vätskekylda maskiner. Den är mycket driftsäker och innehåller inga slitande delar. Man kan montera original startkrans.

Variatorn levereras färdigkalibrerad.

Bilden i höger: Samma variator, men den har gått 700 mil. Inget slitage, samma fjäderlängd som i den nya, viktblocken är som nya och skivorna helt korrekta. Den ursprungliga drivremmen med bredd av 35 mm. Summit 600 SDI.



## Polaris

<b>15-84</b>	Alla 488 cc	1989-
<b>15-84</b>	600 cc 2-cyl liten kona	1997-
<b>15-88</b>	600 cc 2-cyl stor kona	2007-
<b>15-84</b>	600 cc 3-cyl	1996
<b>15-84</b>	700 cc 2-cyl	1997-06
<b>15-84</b>	800 cc 2-cyl	2000-05
<b>15-84</b>	750 cc 4-takt turbo	2006-
<b>18-88</b>	800 cc, stor 32 mm kona	2008-



## Arctic Cat

Liten kona		
<b>15-85</b>	Alla under 700 cc motorer	
Stor kona på alla följande fr.o.m. 2003		
<b>15-86</b>	<b>599 3D 2-cyl. 114 hp 31 mm</b>	2003-
<b>15-86</b>	<b>658 cdi 3-cyl. 110 hp 4-takt, 31 mm</b>	2003-
<b>15-86</b>	<b>698 3D 2-cyl. 140 hp 31 mm</b>	2003-
<b>15-86</b>	<b>794 cc 2-cyl</b>	2002-

Alla kalibreringar hittar du på vår hemsida:  
[www.teolehtimaki.fi/varaosaluettelot](http://www.teolehtimaki.fi/varaosaluettelot)

# Skidoo & Lynx

Kolla också [www.teolehtimaki.fi](http://www.teolehtimaki.fi)

p/n	motortyp	år	obs.
<b>15-81</b>	Rotax 453	MXZ 440 LC X	
<b>15-82</b>	Rotax 593, 500SS	1999-2005	<b>15-81</b> 2006-
<b>15-81</b>	Rotax 693 2-cyl	1999-	
<b>15-81</b>	Rotax 699 3-cyl	1996-	
<b>15-81</b>	Rotax V-810	2007-	
<b>15-81</b>	Rotax V-1000	2003-	
<b>15-81</b>	Rotax V-1200	2009-	
<b>15-82</b>	Rotax 493, 494	1996-	
<b>15-82</b>	Rotax 593HO,600 SDI	2003-2005	<b>15-81</b> 2006-
<b>15-81</b>	Rotax 600 ACE, E-Tec	2009-	TRA monteringsbult
<b>15-82</b>	Rotax 670	1993-	
<b>15-84</b>	Rotax 582, 583, 643	1993-	ej startkrans
<b>15-82</b>	Rotax 800HO, 800R	alla	
<b>15-82</b>	Rotax 800 E-Tec	finns ej	kommer 2014

Modeller 15-81 och 15-82, stor kona, startkrans. Utan startkrans man kan använda båda modeller. 15-84, liten kona.

## Yamaha

15-83	500, 494 cc	1994-2001
15-83	600 cc 2-cyl	1994-1999
15-83	600 cc 3-cyl	1999-2002
15-83	700 cc	1996-2002
4-takt,	4-takt	
15-83	499 cc 80 hp	2007-
15-83	973 cc 120 hp	
15-83	998 cc Rx 1	2003
15-83	1049 cc	2008-
<b>15-83</b>	700 cc-	alla



## P80 fjädrar

P/N	CVTech	N min/ 72 mm	N max / 45 mm	längd	A dia.	i
<b>15-91</b>	<b>0451-1135</b>	900	1300	134,0	5,50	6,75
<b>15-92</b>	<b>0451-1136</b>	900	1600	109,0	6,00	6,00
<b>15-93</b>	<b>0451-1132</b>	810	1150	143,0	5,50	8,00
<b>15-94</b>	<b>0451-1134</b>	742	1612	95,0	6,00	5,00
<b>15-95</b>	<b>0451-1109</b>	300	1100	82,0	6,00	5,25
<b>15-96</b>	<b>0451-1114</b>	400	900	94,0	5,50	5,80
<b>15-97</b>	<b>0451-1133</b>	800	1300	121,0	5,50	
<b>15-98</b>	<b>0451-1113</b>	400	700	111,0	4,90	
<b>15-99</b>	<b>0451-1128</b>	700	900	164,0	5,00	8,25



## P50 Variator

Numret är blått

Alla kalibreringar hittar du på vår hemsida:

[www.teolehtimaki.fi/varaosaluettelot](http://www.teolehtimaki.fi/varaosaluettelot)

Hemsidan uppdateras kontinuerligt!

Numero	S4B	P50 numero	CVTech	PTO	V-rem	x	Använd
15-02	5913B	0403-0002		2,50	31,7		<b>15-02</b>
15-03		0403-0003	15-0147C	8,77	34,8	8	<b>15-03</b>
15-04		0403-0004	15-0148C	8,77	34,8	8	<b>15-04</b>
15-05	0513B	0403-0005		11,5	33,3	6	<b>15-05</b>
15-06	8113B	0403-0006	15-0149C	6	34,9		<b>15-06</b>
15-09	9513B	0403-0009		11,5	34,9	6	<b>15-04</b>
15-10	9713B	0403-0010		5	33,3		<b>15-10</b>
15-11	9213B	0403-0011	15-0151C	1,5	34,9		<b>15-11</b>
15-18	9113B	0403-0018	fläns	4,99	34,9		<b>15-18</b>
15-22	3113B	0403-0022	fläns	0,06	32,7		<b>15-22</b>

**S4B variator har utgått.** X = startkrans skruv, 6 mm eller 8 mm

## P50 fjädrar

P/N	CVTech	N min /	N max /	längd	A dia	obs
		72 mm	45 mm	mm	mm	i
<b>15-51</b>	0151-0003	730 / <b>730</b>	987 / <b>1056</b>	<b>132</b>	4,88 / <b>5,50</b>	<b>8,10</b>
<b>15-52</b>	0151-0002	618 / <b>708</b>	1050 / <b>1115</b>	<b>108</b>	5,26 / <b>5,50</b>	<b>6,00</b>
<b>15-53</b>	0151-0006	500 / <b>499</b>	1070 / <b>1142</b>	<b>93</b>	5,71 / <b>6,00</b>	<b>6,10</b>
<b>15-54</b>	0451-1118	500 / <b>501</b>	700 / <b>832</b>	<b>114</b>	4,50 / <b>5,50</b>	<b>8,10</b>
<b>15-55</b>	0451-1129	700 / <b>708</b>	1100 / <b>1056</b>	<b>127</b>	5,26 / <b>5,50</b>	<b>7,50</b>
<b>15-56</b>	0451-1137	595 / <b>604</b>	852 / <b>929</b>	<b>122</b>	4,88 / <b>5,50</b>	<b>8,10</b>

Dessa fjädrar man kan använda också i P80 variatoren

Den blå fjäderns konstant är något högre på maxvarv än CVTech fjäderns. Kalibrering kan ändras genom att lägga till viktbricka i varje viktblock Kom i håg: en bricka motsvarar ungefär 100 varv /min. Om motorns max varvtal avviker det som fabriken angett för den aktuella motortypen bör man även kontrollera sekundärvariatorns fjäderförspänning och variatorernas linjering.

Motorns prestanda blir aldrig bättre än variatorernas kalibrering tillåter.

**Avdragare av variatorer:**

**P50, P80, TRA, M14x1,5**

**Produktnummer: 18-212**

**Verktyg**

**P50, P80, ATV-variator**

**Produkt nummer: 18-300**



## ALT-variator



15-0513A

15-3913A

15-3113A

15-2913A

Variator	PTO typ	PTO just. mm	V-rem mm	passar på m.fl
15-0513A	Kona 30 mm 1/10	- 2,0	33,3	Lynx, Skidoo
15-0613A	Gänga 7/8" 14UNF		33,3	Alpine
15-0913A	Gänga 7/8" 14UNF		31,7	Alpine
15-1013A	Gänga 3/4" 14UNF		31,7	Elan
15-1213A	Kona 30 mm 1/10	- 6,35	31,7	Lynx, Skidoo
15-1713A	Gänga M28x1" Syl 24,6		31,7	Yamaha
15-2813A	Kona 30 mm 1/10	+14,27	34,9	Polaris
15-2913A	Kona 30 mm 1/10	- 12,7	31,7	Yamaha
15-3113A	Kona 30 mm 1/10	- 12,7	31,7	Yamaha
15-3913A	Kona 30 mm 1/10	- 12,7	33,3	Rotax 253
15-5013A	Hål 1" och kil 1/4"		31,7	

## Reservdelar för ALT modeller



16-11



16-06



16-09



16-08



18-060  
18-090



16-07



16-02

Nummer	CVTech	längd mm	Dia	min. Nm	max. Nm	i
<b>19-12</b>	<b>X-5243212</b>	<b>70</b>		<b>108</b>	<b>1677</b>	Terri
19-02	X-5243300	76,8	6,30	455	1852	6,00
19-01	X-5243302	78,5	6,30	526	1879	6,25
19-05	X-5243308	89		922	2090	
<b>16-20</b>	X-5218300	76,0	5,50	223	978	6,00
<b>16-21</b>	X-5218400	100,0	5,50	832	1535	6,25

Alla kalibreringar på hemsidorna:  
[www.teolehtimaki.fi/varaosaluettelot](http://www.teolehtimaki.fi/varaosaluettelot)



Avdragare för ALT variator  
 gänga: 9/16 -18  
**Produkt nr: 18-209**

**S4B: reservdelar**



**Avdragare för S4B : p/n 18-210  
gänga: 9/16 -18**



**18-030**



**18-100**



**17-050**



**17-051**



**18-060  
18-090**



**18-140  
18-200**

**P50: reservdelar**



**19-100**



**19-120**



**19-170 skruv  
19-171 polaris  
19-140 bricka  
17-112 mutter  
18-160 bricka**



**19-050**



**17-090**



**19-130**



**19-030**



**16-08**



**16-07**

**P80: reservdelar**



**19-080**



**19-084**



**19-081  
/ 3 kpl**



**19-082 / 12**



**19-083**



**19-085**

**Reservdelar för sekundärvariator**



**14-16  
cam**



**14-10  
ring**



**längd 39 mm  
hål 38 mm  
yttre dia 44,5 mm**

**14-08  
glidlager**



**14-15  
cam 14- modeller**

# Trailbloc - ATV

Färdigkalibrerade variatorer

Tillverkare:

**CVTech-IBC**



cc	<b>Polaris</b> model	år	kalibrerad	body
350	350L, Trail Boss 350	90-93	13-0042	23-0006
400	400L, Big Boss 6x6, Scrambler	94-02	13-0042	23-0006
	Sport 400L 2x4, Sportsman 400	94-05		
	Trail Blazer, Xplorer, Xpress	96-03		
425	Magnum 425 alla	95-98	13-0043	23-0006
455	Sportsman 450	06-07	13-0042	23-0006
499	ATP 500 HO 4x4,	04-05	13-0012	23-0002
	Sportsman EFI EBS alla	06-09		
	Sportsman 500 HO EBS, 500 DUSE	01-05		
	Sportsman 500 EN, Worker EBS	98-00		
499	Scrambler 500 all	98-09	13-0040	23-0006
	Sportsman 500 HO, EFI	01-08		
499	Big Boss 6x6	98-02	13-0043	23-0006
	Magnum 500 4x4	2000		
	Scrambler 500 4x4, Xplorer 500	1997		
	Sportsman 500, 500 6x6	96-08		
600	Sportsman 600 Twin	03-05	13-0009	23-0001
700	Sportsman 700 Twin EBS	03-04	13-0009	23-0001
700	Sportsman MV7 EBS	2005	13-0010	23-0001
	Sportsman 700 EFI EBS	04-08		
800	Sportsman 800 EFI EBS	05-07	13-0011	23-0001
800	Sportsman 800 EFI	2007	13-0047	23-0005
697	<b>Suzuki</b> Twin Peaks 700 4x4	04-05	13-0007	23-0003
633	<b>Arctic Cat</b> 650 V-Twin 4x4 automatic	02-06	13-0007	23-0003
	<b>Canam</b>			
400	Outlander 400 HO	02-09	12-0066	23-0009
500	Outlander 500 HO, Renegade	07-10	13-0033	23-0011
650	Outlander 650 HO all	06-10	13-0034	23-0011
800	Outlander 800 HO, 800 R	06-11	13-0067	23-0010
800	Renegade 800 HO, 800 R	07-11	13-0068	23-0010
1000	Commander 1000	11-12	12-0075	23-0013
1000	Outlander/Renegade 1000	2012	12-0085	23-0010
	<b>Honda</b> Pilot	alla	ALT variator	
300	<b>Kawasaki</b> Prairie 300	99-02	P50 variator	
400	Prairie 400	97-02	P50 variator	
633	Brute Force 4x4 alla	05-10	13-0007	23-0003
697	Prairie 700 4x4 alla	04-06	13-0007	23-0003
749	Brute Force 750 4x4 alla	05-07	13-0007	23-0003

11 lamel	längd	13 lamel	längd	15 lamel	längd
45-064	64	46-064	64	50-064	64
45-066	66	46-066	66	50-066	66
45-068	68	46-068	68	50-068	68
45-070	70	46-070	70	50-070	70
45-072	72	46-072	72	50-072	72
45-074	74	46-074	74	50-074	74
45-090	90	46-076	76	50-076	76
<b>Kuggkedja</b>		46-102	102	50-078	78
		46-104	104		
		46-106	106		
		46-108	108		

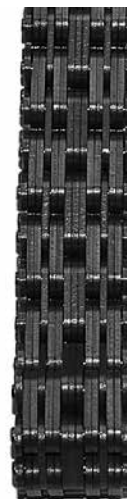

### 3/4" Hyvo kedja

### 7/8" Hyvo kedja

3/4" bredd	längd	3/4" bredd	längd		7/8" bredd	längd
52-66	66	52-80	80		53-70	70
52-68	68	52-82	82		53-72	72
52-70	70	52-86	86		53-74	74
52-72	72	52-90	90		53-76	76
52-74	74	52-92	92		53-78	78
52-76	76	52-94	94		Original	
52-78	78				Borg Warner kedja	

### Kedjedrev, Ski-doo, Lynx

11 bredd	Z	13 bredd	Z	15 bredd	Z	nedre 13	Z	nedre 15	Z
45-016	16	46-016	16						
45-017	17	46-017	17			55-43	43	58-43	43
45-018	18	46-018	18			55-44	44		
45-019	19	46-019	19	50-019	19	55-45	45	58-45	45
45-020	20	46-020	20	50-020	20				
45-021	21	46-021	21	50-021	21				
45-022	22	46-022	22	50-022	22				
45-023	23	46-023	23	50-023	23				
45-024	24	46-024	24	50-024	24				
		46-025	25	50-025	25				
		46-026	26						

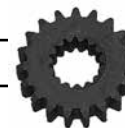

### Kedjedrev, 7/8"-13 spline

Arctic Cat alla, ej Diamond drive, Polaris ända till 1996

11-bredd	Z	11-bredd	Z	13-bredd	Z	13-bredd	Z
47-016	16	47-021	21	48-016	16	48-021	21
47-017	17	47-022	22	48-017	17	48-022	22
47-018	18	47-023	23	48-018	18	48-023	23
47-019	19	47-024	24	48-019	19	48-024	24
47-020	20			48-020	20		

# Rotax = Lynx, Skidoo vevaxellager

1-CYL F/C		MAG	MITTENLAGER	PTO
247 F/C ELAN	1985-96	83464C ( 6305 C4 )		83464C ( 6305C4 )
253 F/C	1985-92	6206 GPC4		6206 GPC4
277 F/C	1980-84	83464C		6306 PC4
277 F/C	1993-08	6206 C4		6306 PC4
<b>2-CYL F/C</b>				
377-447 Kärjet	1980-81	6207 GPC4	6305 NRC4 x 2	6207 GPC4 x 2
377-447 Nippon D	1982-89	6207 GPC4	6305 NRC4 x 2	6206 GPC4 x 2
377-447 F/C	1990-96	6207 GPC4	6207 GPC4 x 2	6207 GPC4 x 2
377-447 F/C	1997-05	6207 GPC4	6207 GPC4 x 2	6207 PC4 x 2
503 Kärjet	1979-81	6207 GPC4	6305-NRC4 x 2	6206 GPC4 x 2
503 Nippon D	1982-89	6207 GPC4	6305 NRC4 x 6206 GPC4	6206 GPC4 x 2
503 F/C	1990-96	6207 GPC4	6207 GPC4 x 2	6207 GPC4 x 2
503 F/C	1997-03	6207 GPC4	6207 GPC4 x 2	6207 GPC4 x 2
550 Top needle	2003-05	6207 GPC4	6207 PC4 x 6207 PC4	6207 GPC4
640 F/C	1970-82	6306 NRC4	6306 NRC4	6306 NRC4
<b>2-CYL L/C</b>				
440 MXZ-X, 500	2000-05	6206 PC4 x 2	6206 PC4 x 2	6207 PC4 x 2
444 L/C	1977-79	6206 GPC4	6305 NRC4 x 2	6206 GPC4 x 2
454 L/C	1995-98	6206 PC4 x 2	6206 PC4 x 2	6207 PC4 x 2
462 L/C SP-SS	1984-86	6206 GPC4	6305 NRC4 x 6206 GPC4	6206 GPC4 x 2
467 L/C	1985-95	6206 GPC4 x 2	6305 NRC4 x 6206 GPC4	6207 GPC4x 2
494 L/C T-Crank	1996-00	6206 PC4 x 2	6206 PC4 x 2	6207 PC4 x 2
500 L/C	2003	6206 PC4 x 804551	6206 PC4 x 2	FAG x 6207 PC4
532-536-582-583	1985-99	6206 GPC4 x 2	6305 NRC4 x 6206 GPC4	6207 NRC4 x 2
600 L/C C-Seal 63	1999	6206 PC4 x 2	6206 GPC4 x 2	6207 PC4 x 2
600 L/C C-Seal 66	2000-02	6207 PC4 x 2	6206 GPC4 x 2	FAG x 6207 PC4
500SS, 600 C-S 66	2003-07	804551 x 6206 PC4	6206 PC4 x 2	FAG x 6207 PC4
600 MXCX RS	2008	6207 PC4 x 2	6207 PC4 x 2	804662E x 6208 PC4
600 HO SDI Key12	2004-07	FAG x 6207PC4	6207 PC4 x 2	6208X x 804662E
600 HO C-Seal 76	2003-05	FAG x 6207PC4	6207 PC4 x 2	FAG x 6207 PC4
600/593 E-Tec	All	FAG x 6207PC4	6207 PC4 x 2	6208X x 804662E
617-643 L/C	1991-92	6206 GPC4 x 2	6305 NRC4 x 6206 GPC4	6207 GPC4 x 2
670 L/C	1993-97	6206 PC4 x 2	6206 PC4 x 2	6207 GPC4 x 2
670 L/C	1998-99	6207 PC4 x 2	6206 PC4 x 2	6207 PC4 x 2
700 L/C C-Seal 79	1999-00	6207 PC4 x 2	6207 PC4 x 2	6208 PC4 X 2
700 L/C C-Seal 76	2000	6207 PC4 x 2	6207 PC4 x 2	6208 PC4 x 2
700 L/C Mgt seal	2001-02	FAG x 6207PC4	6207 PC4 x 2	6208 PC4 x 2
700 L/C C-Seal 76	2003-05	FAG x 6207PC4	6207 PC4 x 2	6208 PC4 x 804662E
800 L/C	2000-03	FAG x 6207PC4	6207 PC4 x 2	6208-PC4 X 2
800 L/C HO, R,	2003-07	FAG x 6207PC4	6207 PC4 x 2	6208X x 804662E
1000 L/ HO	2005-07	804662E x 2	6208 PC4 x 2	804662E x 2
<b>3-CYL L/C</b>				
600 L/C	1995	6208-PC4	6206 PC4 x 4	6208 PC4 x 2
600 L/C	1996-97	6208-PC4	6206 PC4 x 4	6208 PC4 x 2
600-700 L/C CK3	1998-00	6208-PC4	6206 PC4 x 4	6208 PC4 x 2
779 L/C	1993-96	6208-PC4	6207 GPC4x 4	6208 PC4 x 2
809 L/C	1997-03	6208-PC4	6207 PC4 x 4	6208 PC4 x 2

**Rotax****Part number****Dimensions**

Beställningsnummer	Mått	Beställningsnummer	Mått
6305 C4 = 83464 C	25 X 62 X 17	6207 C4	35 X 72 X 17
6305 NRC4	25 X 62 X 17	6207 PC4	35 X 72 X 17
6306 NRC4	30 X 72 X 19	6207 GPC4	35 X 72 X 17
6206 C4	30 X 62 X 16	804551 = 6206 GSPC4	30 X 62 X 18/19
6206 PC4	30 X 62 X 16	804662E = 6208 GSPC4	40 X 80 X 21
6206 GPC4	30 X 62 X 16	6208 PC4	40 X 80 X 18
FAG = 804661BL178	35 X 72 X 17/18	6208X = 6208X28YR1N	40 X 80 X 23
FAG = 6207 GSPC4	35 X 72 X 17/18	6208 GSPC4	40 X 80 X 21

**Yamaha****vevaxellager**

<b>1-CYL F/C</b>		MAG	MITTENLAGER	PTO
250 ET		6206 C4		6306 NRC4
250 BRAVO		6305 H/INDY		6306 N9C4
<b>2-CYL F/C</b>				
300-340 F/C ET		83464-C	83548D-9	6306 N9C4
400-410 F/C		83464-C	83548D-9 x 83548D-9	OEM N/A
440 SS		83548D9		DG3278JSO x 2
485 F/C	1984-98	DG3268B	DG3268-B x DG3268-B	83A779 x 2
500 F/C	1999-02	DG3268B		83A779 x 2
535-540 F/C VK		83548D9	83548D-9 x 83548D-9	DG3278JSO x 2
<b>2-CYL L/C</b>				
500-570-600cc	1987-96	83B207		
500-600 L/C	1997-	83B207		
<b>3-CYL L/C</b>				
700 L/C SX	1997	62/32GPC4 x 2	62/32GPC4 x 2 x OEM N/A	OEM N/A
600-700 L/C SX	1998-06	OEM N/A	OEM N/A	OEM N/A
600-700 L/C SRX	1998-99	OEM N/A	OEM N/A	OEM N/A
600-700 L/C SRX	2000-02	OEM N/A	OEM N/A	OEM N/A
700 L/C VIPER	2002-06	OEM N/A	OEM N/A	OEM N/A
<b>4-CYL L/C</b>		vänster	mittenlager	höger
750 / 8AX-11401	1992-94	6206PC4	6206PC4 x 4 x 6305GPC4	OEM N/A
750 / 8AX-11402	1992-04	6206PC4	6206PC4 x 4 x 6305GPC4	83464C
800 / 8BU-11401	1995-97	6206PC4	6206PC4 x 4 x 6305GPC4	OEM N/A
800 / 8BU-11402	1995-97	6206PC4	6206PC4 x 4 x 6305GPC4	OEM N/A

<b>Beställningsnummer</b>	<b>mått</b>		<b>Beställningsnummer</b>	<b>mått</b>
6206 C4	30 X 62 X 16		83464C	25 X 62 X 17
6206 PC4	30 X 62 X 16		83A779	32 X 78 X 19
6305 H/INDY	25 X 68 X 17		83548D-9	32 X 62 X 16
6306 NRC4	30 X 75 X 19		83B207	32 X 72 X 30
6206 N9C4	30 X 72 X 19		DG3268-B	32 X 68 X 16
62/32 GPC4	32 X 65 X 17		DG3278JSO	32 X 78 X 16,5

# Polaris vevaxellager

1-CYL F/C		MAG	CENTER X 2	PTO
250 F/C	1985-95	6206 C4		6206 C4 x 2
2-CYL F/C				
340 F/C Injection	alla	6206 C4	6007 PC4 x 2	6206 GPC4 x 6206 PC4
440-500 F/C		6206 PC4	6206 PC4 x 2	6206 GPC4 x 6206 PC4
440 XCF-550 F/C	1998-07	5206 S9	6206 PC4 x 2	6207 GPC4 x 6207 PC4
2-CYL L/C				
440-500L/C		6206 PC4	6206 PC4 x 2	6206 GPC4 x 6206 PC4
440 L/C XCR only	1994-95	6206 PC4	6206 PC4 x 2	6206 GPC4 x 6206 PC4
440 L/C XCR	1996-97	6206 PC4	6206 PC4 x 2	62/32 PC4 x 62/32 GPC4
500 L/C	1996-00	6206 PC4	6206 PC4 x 2	62/32 PC4 x 62/32 GPC4
500 LC	2000-10	5206 S9	6206 PC4 x 2	62/32 PC4 x 62/32 GPC4
440 LC PRO X	1998-03	6207 PC4	DG3572201C4	DG3572201C4 x 6207PC4
440 LC PRO X	2004-07	6207 PC4	DG3572201C4	DG3572201C4 x 6207PC4
500-600 L/C USA	1998-03	6207 PC4	DG3572201C4	6207/9BA9T x 6207 PC4
500-600 L/C PRO X	2004-09	6207 PC4	DG3572201C4	6207/9BA9T x 6207 PC4
600-700 L/C	1997-98	6207 PC4 x 2	6207 PC4 x 2	6207 GPC4 x 6207 PC4
600 HO	2007-09	DG3572201C4	DG3572201C4	6207/9BA9T x 2
600 IQ	2008	DG3572201C4	DG3572201C4	6207/9BA9T x DG3572201C4
700 LC Dragon-RMK	2008-10	DG3572201C4	DG3572201C4	6207/9BA9T X 2
600-700 L/C	1999-05	6207 PC4 x 2	6207 GPC4 x 2	6207/9BA9T x 6207 PC4
600-700 L/C HD pto	1999-05	6207 PC4 x 2	6207 GPC4 x 2	5207 S9C4 x 6207 PC4
700 L/C Classic	2006-10	6207 PC4 DG3572201C4	6207 GPC4 x 2	5208C4 x 2
700 L/C Frontier 4-t	2002-04			6207/9BA9T x 6207 GPC4
800 L/C USA	2000-05	6207 PC4 x 2	6207 GPC4 x 2	6207/9BA9T x 6207 PC4
800 L/C Heavy duty	2000-05	6207 PC4 x 2	6207 GPC4 x 2	5207 S9C4 x 6207 PC4
900 L/C	2005-06	6207 PC4 x 2	6207 GPC4 x 2	5208C4 x 2
3- CYL L/C				
580 L/C mono block	1992-94	6206 PC4	6206 PC4 x 4	6206 GPC4 x 6206 PC4
600 L/C mono block	1995-97	5206 S9	6206 PC4 x 4	6206 GPC4 x 6206 PC4
600 L/C oil jet	1997-00	5206 S9	6206 PC4 x 4	6206 GPC4 x 5206S9
600 SP-680 L/C	1996	35BG06 S9	6007 PC4 x 4	6207 GPC4 x 6207 PC4
650 L/C CARB-RXL	1985-98	5206-S9	6206 PC4 x 2	6206 GPC4 x 5206S9
600-680-700 XRC	1997-98	35BG06 S9	6007 PC4 x 4	6207 PC4 x 6207 GPC4
750-800 L/C Storm	1993-98	6207 PC4 x 2	6207 PC4 x 4	6307 GPC4 x 6307 PC4
700-800 XCR	1999-03	35BG06 S9	6007 PC4 x 4	6207 GPC4 x 6207 PC4

Beställningsnummer	Mått	Beställningsnummer	Mått
6206 C4	30 X 62 X 16	5206 S9	30 X 62 X 23,8
6206 PC4	30 X 62 X 16	5207 S9C4	35 X 72 X 27
6206 GPC4	30 X 62 X 16	5208 C4	40 X 80 X 30,2
6207 PC4	35 X 72 X 17	62/32 GPC4	32 X 65 X 17
6207 GPC4	35 X 72 X 17	35BG06 S9	35 X 62 X 23,8
6207/9BA9T	35 X 72 X 24	DG3572201C4	35 X 78 X 20
6307 PC4	35 X 80 X 21	6307 GPC4	35 X 80 X 21

# Arctic Cat vevaxellager

<b>2-CYL F/C</b>	Years	MAG	MITTENLAGER	PTO
340 F/C inj	1987-94	83350A ( DG2555 )	83350A (DG2555 )	83519D x 83519D
440 F/C	1980-06	83519D	83519D x 83519D	83519D x 83519D
370-Z440	1999-08	83519D	83519D x 83519D	83519D x 83519D
440 F/C	1988-00	83519D	83519D x 83519D	83519D x 83519D
440F/C Snopro	2002-03	83519D	83519D x 83519D	OEM 3006-096
500 F/C	Kaikki	83519D x 83519D	83519D x 83519D	83519D x 83519D
570 F/C	2002-05	6306N9C4 /	6306N9C4 x 2	35NQ5528W11
<b>2-CYL L/C</b>				
440 L/C		83519D x 83519D	83519D x 83519D	OEM N/A
440 L/C	1987-89	83519D x 83519D	83A073B x 83A073B	OEM N/A
440 L/C ZR	1995	83A073-9	83A073B x 83A073B	40NQ 6430W1
440 L/C ZR	1996-00	83A073-9	83A073B x 83A073B	40NQ 6430W1
440L/C Snopro	2003-04	306/1DYR1W	83B551A 30mm x 2	40NQ 6430W1S
F-5	2003-07	306/1DYR1W	83B551A 30mm x 2	40NQ 6430W1S
5-600ZR T-	1998-02	83A073-9	83A073B x 83A073B	40NQ 6430W1
530 L/C		83519D	83A073B x 83A073B	OEM N/A
550 L/C	1991-92	83A073-9	83A073A x 83A073B	40NQ 6430W1
550 L/C	1993-05	83A073-9	83A073A x 83A073B	40NQ 6430W1
580 L/C	1993-05	83A073-9	83A073A x 83A073B	40NQ 6430W1
600 ZR	2000-04	6306/4DYR1	83B551A 30mm x 2	40NQ 6430W1
650 L/C W-C	1988-90	83B551A 35mm	83B551A 35mm x 2	OEM N/A
700 L/C	1991-93	83B551A 35mm	83B551A 35mm x 2	40NQ 6430W1
700 L/C	1994-97	83B551A 35mm	83B551A 35mm x 2	40NQ 6430W1
F6-F7	2003-05	22075/1DYR1W	83B551A 35mm x 2	40NQ 6430W1S
800-900 ZR	2000-06	307/1DYR1W10	6307R/1DYR x 2	3208/1DW11CA
<b>3-CYL L/C</b>				
600 L/C ZRT	1995-02	83A073B	6207R9x2, 83A073Bx2	40NQ 6430W1
800-900 L/C	1993-00	6306/4DYRI	6209/1DRIN X 4	6209/1DRIN X 2
1000 L/C	1998-02	6306/4DYRI	6209/1DRIN X 4	6209/1DRIN X 2

<b>Beställningsnummer      mått</b>		<b>Beställningsnummer      mått</b>	
22075/1DYR1W	35 X 75 X 23	DG2555	25 X 55 X 15
3208/1DW11CA	40 X 83 X 30	35NQ5528W11	35 X 55 X 28
306/1DYR1W	30 X 75 X 19	40NQ6430WI	40 X 64 X 30
307/1DYR1W10	35 X 83 X 21	40NQ6430W1S	40 X 64 X 30
6209/1DRIN	45 X 90 X 19	83519D	30 X 65 X 16
6207R9	35 X 72 X 17	83A073-9	30 X 72 X 19
6306/4DYR1	30 X 72 X 19	83350A	25 X 55 X 15
6306/N9C4	30 X 72 X 19	83B551A 30 mm	30 X 75 X 17
6307R/1DYR	35 X 83 X 21	83B551A 35 mm	35 X 75 X 17

## Vevaxelkonor, Rotax

09-187	Rotax 503	tapp 24 mm
09-1880	Rotax 670	tapp 24 mm
09-1881	Rotax 800HO	tapp 27 mm
09-1882	Rotax 500 + 600	tapp 24 mm
09-1883	Rotax 600 + 700	tapp 27 mm
09-1884	Rotax 800R	tapp 30 mm



## Vevaxelkonor, Polaris

09-241	Polaris XC500+XC600	tapp 28 mm
09-185	Polaris XC800	tapp 27 mm
09-186	Polaris XC700	tapp 28 mm



## Packboxar/ drivaxel-Lynx växellåda



36-00	AS	25	52	07
36-01	AS	25	52	10
36-02	AS	26	52	07
36-04	AS	26	52	08
36-05	AS	20	40	07
36-06	AS	25	42	07

## Packboxar



09-501731    09-501372    09-501497    09-190    09-501622

09-501731	30 X 42 X 7 (09-113) Rotax
09-167	30X62X7/8 Rotax ( ej bild )
09-501372	35 X 72 X 7/8 ( 09-165 ) Rotax
09-501497	40 X 80 X 7 (09-170) Rotax
09-190	ATS DUO 34.6x76x2.6/10.2, centrum
09-501622	40 X 84 X 2,6 / 10,2 Rotax, centrum
09-501584	35 X 72/76 X 7/9 Polaris
09-501909	24 X 44 X 11,4 Polaris
09-501414	30 X 62 / 63,7 X 7 (14202) Polaris



09-501584    09-501909

# Shortblock, kit

Tillgängliga med kort leveranstid

Short block inkluderar:

- Renoverat vevhus
- Nya kolvar
- Renoverad vevaxel
- Ny cylinderbeläggning
- Nya packningar
- Nya kullager
- 0,5 l inkörningsolja
- Slidmatningsaxel (i aktuella fall)
- Notera: Priset inkluderar inte utbytesstommen



## Renoverade vevaxlar

### Arctic Cat, vid förfrågan



Renoverade vevaxlar:

- samtliga kul/rullager
- mittre packboxar
- vevstakar
- riktade enligt originalspecifikationer
- 1-års garanti
- Med kullagerfett (i aktuella fall)

### Rotax



Rotax 600E



Rotax 1000

### Polaris



600/700 RMK



800 RMK

### Yamaha



Viper 02-06



Viking II & III

# Rotax, Lynx & Skidoo Vevaxel, renoverade

Lagerförda

F/C; Fläktkyld

# del	cc	år	modell	obs	nållager
1-cylinder F/C motorer					
60-247KA	247	85-96	Elan 250 & Elan 250 DLX	ram lager	35-505
421000001					
<b>60-253KA</b>	253	85-92	Citation, Safari, Tundra LT, Lynx 250		35-505
421000002			Nordik 300, 300R		
<b>60-277KA</b>	277	93-05	Tundra II, LT, R		35-505
421000031	420995301				
<b>60-277KB</b>	277	06-09	Freestyle, Scandik, Tundra 300		35-505
421000639	420995307				
2-cylinder Free-Air engine					
60-340KA	340	1975	RV 340		35-505
421000014			centrum ramlager utan seeger ring		
60-340KA	340	76-77	RV 340		35-505
421000013			centrum ramlager med seeger ring		
2-cylinder F/C engine					
60-343KA	343	75-79	Everest RV/TNT, Olympique 340	kona PTO	35-505
421000010			345, 346, 400		
60-440KA	440	75-79	Everest, Olympique TNT 440	kona PTO	35-505
421000004					
60-377KA	377-	80-81	Citation 4500 & SS, Lynx modeller	brytare	35-505
421000029	477				
60-377KB	377-	82-89	Nordik 500, Safari 377, 447, Scout	Nippo	35-505
421000028	447		Lynxit, Trapper 500, Skandic 377		
<b>60-377KC</b>	377-	90-96	Formula S, Nordik 500, Nordik 377R		35-505
421000009	447		Scandik 377/R, Touring, Lynx		
<b>60-447KA</b>	377-	97-07	Lynxit, Formula S/DLX, GTour 380		35-505
421000154	420889630		GSX-GTX 380, Legend 380, MXZ 440		
	447		Scandic 380/440/LT, Touring E/LT		
60-503KA	503	79-81	Blizzard 5500, Everest 500, Lynx	brytare	35-505
421000033					
60-503KB	503	82-89	Alpine 503, Lynxit, Trapper 600		35-505
421000032			Scandic 503, Cheyenne, Safari 503		
<b>60-503KC</b>	503	90-96	Alpine II, Lynxit, Nordik 600		35-505
421000011	420996445		Scandic WT, Scandic II, 503R, SLT		
<b>60-503KD</b>	503	97-03	Lynxit, Formula S, Legend, MXZ 500		35-505
421000155	420888390/1		Scandic SWT, WT, Touring E, LT, SLE		
<b>60-550KA</b>	550	03-09	Scandic 550, SUV, WT, SWT, MXZ	fett,	35-524
421000601	420 889 062		Freestyle, GSX-GTX, Summit 550	nållager	
<b>60-550KB</b>	550	10-12	Scandic, Tundra SUV 550, MXZ, TNT	fett	35-507
421000673	420 889 067		Renegade, GT 550,	nållager	

# Rotax, Lynx & Skidoo Vevaxel, renoverade

## Lagerförda L/C; Vätskekylda

# del	cc	år	modell	obs	nållager
2-cylindrar L/C motorer					
60-440KB	440-	00-05	MXZ X 440, 440 Racing	fett	35-503
421000567	500; 420885462; Formula DLX, MXZ 500, Legend 500				
<b>60-500KA</b>	494	96-00	Scandic 500 WT, Lynx, MXZ 500	nållager	35-503
421000151	420886933		Formula Z 500, Summit 500, GT 500		
<b>60-582KA</b>	582	83-99	Lynxit, Formula STX, DLX, Z583,		35-505
421000021	Plus, Plus X, LT, XTC, Mach I, Summit				
<b>60-600KA</b>	500ss	03-12	Lynx WT, SUV, Scandic 600, MXZ 600	fett, 66 mm	35-507
421000611	420888757		MXZ SS, GTX SS, alla SS motorer	centrum backbox	
60-600KB	600	1999	MXZ & Summit 600	fett, 62 mm	35-507
421000553	420888250			centrum packbox	
60-600KC	600	00-02	Formula DX, Z600, Scandic 600	fett, 62 mm	35-507
421000563	420888252/1		MXZ, Legend 600, Summit 600	centrum packbox	
<b>60-600KD</b>	600ho	03-07	Summit 600HO, Renegade 600HO/X		35-507
421000609	420889091		MXZ 600, Rev 600HO		
60-600KR	600rs	08-10	MXZ MXZ X 600 RS	fett	35-507
421000576					
<b>60-600KE</b>	600	04-12	420890950/1, Alla SDI motorer	fett	35-507
421000622	4210664, 420890956/5/4;		Alla Etek motorer	kil KI 12	
60-670KB	670	95-99	Formula SS, Z670, MXZ 670	kil KI 06	35-507
421000046			Mach 1, Summit 670, Lynx	nållager	
60-700KA	700	99-00	MXZ 700, Summit 700	fett, 79 mm	35-507
421000570				centrum backbox	
60-700KB	700	2000	MXZ 700, Formula 700 DLX, Z700	fett, 76 mm	35-507
421000569			Summit 700 SB, HM, Lynx	centrum packbox	
60-700KC	700	01-02	Formula DLX, Legend 700	fett, 76 mm	35-507
421000574	420888266		GT 700, MXZ, Summit 700, Lynx	centrum packbox	
<b>60-600KD</b>	700	03-07	GT 700, MXZ, Summit 700,	fett, 76 mm	35-507
421000609	420889091		Legend 700, Lynx	centrum backbox, 2xPTO bric	
<b>60-800KA</b>	800	00-02	GT 800, Legend 800, MXZ 800	fett, 76 mm	35-507
4210573	420888402		Summit 800, HM, Lynx	centrum packbox	
<b>60-800KC</b>	800	04-07	GSX-GTX 800HO, MXZ 800HO	fett, 76 mm	35-507
421000607	420889671		Renegade 800/X, Summit 800/X	centrum packbox ,	
<b>60-800KB</b>	800	03-04	SDI, Grand Touring 800 SDI	fett, 76 mm	35-507
421000606	420889106		Legend 800 SDI	centrum seal, kil KI 12	
<b>60-800KR</b>	800R	06-08	Alla 800 R motorer	fett, bricka	35-415R
421000665	420892562			centrum seal, kil KI 06	
<b>60-800KP</b>	800	09-12	All PTEK engines	fett, bricka	35-415R
421000668	420892567		420893090; 420893093; 420893098	seeger, kil KI 12	
<b>60-1000KA</b>	1000	05-07	Alla 1000 SDI motorer	fett 100 g.	
421000634	420889217				

# Polaris Vevaxel, renoverade

**Lagerförda** L/C; vätskekyld

# del	cc	år	modell	obs	nållager
2-cylinder F/C engine					
61-340KA	340	alla	Sport, GT Sport, SS, Star,		35-522
3083577			Trail SKS,		
<b>61-500KA</b>	440-	alla	Sport, SKS, Touring		35-503
3084585	500		Super Sport, Transport, XCF		
<b>61-550KA</b>	440-	02-11	440 XCF, all 550 engines		35-503
3089483	550				
<b>61-500KB</b>	500	96-00	440 L/C Indy, 500 RMK, SKS, Classic	stefa Pto 32	35-503
3085206	CARB	EFI	Classic Touring	krysskil, Fuji	
<b>61-500KC</b>	500	00-11	Wide Track, 500 Classic/Indy	stefa Pto 32	35-503
3089530				krysskil, stort lager MAG	
<b>61-500KD</b>	500-	98-03	440 XCR, XC, SP, 500 XC, SP, RMK	6 kuggar	35-507
2201234	600		600 Touring, XC, SP, PRo X, RMK	stort bronsdrev	
<b>61-600KA</b>	500-	04-09	500/600 XP, 600 EDGE, 600 RMK,	10 kuggar	35-507
2202520	600		IQ, Switchback, Pro X, Fusion	litet bronsdrev	
<b>61-600KB</b>	600ho	07-13	600 Cleanfire modeller, Rush 600	10 kuggar	35-507
2203320	2204098		600/700 IQ Dragon -08, Widetrack	litet bronsdrev	
<b>61-700KA</b>	700	07-10	600/700 RMK, 700 IQ Dragon	10 kuggar	35-507
2203578			600/700 Switchback		
<b>61-700KB</b>	600-	99-05	600/700 RMK/XC/XC SP	10 kuggar	35-507
2201361	700		600/700 XC/DLC/Classic		
61-700KC	700-	2006	700 Fusion, 700 RMK		35-526
2203110	900		900 Fusion		
<b>61-600KR</b>	600	08-09	600RR Euro, IQ Shift, RMK 144		35-507
2203580					
<b>61-800KA</b>	800	08-12	800 Dragon, IQ, Rush, Assault	10 kuggar	35-526
2203717	2203993, 2204621;				
<b>61-800KB</b>	800	00-05	800 RMK	solid center	35-526
2201554			heavy duty bearings at PTO		

# Yamaha Vevaxel, renoverade

**F/C & L/C;** Lagerförda

# part	cc	year	makes	obs	nållager
<b>62-540KA</b>	535	79-13	EC540, SR540, XL540		35-521
8H8114000	540	F/C	Viking II and III alla årsmodeller		
<b>62-570KA</b>	570	87-96	EX 570, EX 570 SX		35-507
82M11400	500, 600	L/C			
<b>62-600KA</b>	500-	97+	Venture 500/600, SX 600, SXR 500		35-507
82R11400	600		Venture Lite 500, Mountain Max 600		
<b>62-700KA</b>	700	02-06	SXV Viper / ER		35-507
8EK114000	3-syl				

# Vevstake, Rotax

<b>1-cyl F/C</b>					
cc	år	PTO	centrum	MAG	nållager
253	1985-		722-2500		35-505
<b>2-cyl F/C</b>					
377-447	1990-07	722-2503		722-2503	35-505
503	1979-	722-2504		722-2504	35-505
550	2003-	722-2515		722-2515	35-524
<b>2-cyl L/C</b>					
440-500	2000-06	722-2505AP		722-2505AM	35-503
434-444	1975-80	722-2504		722-2504	35-505
454	1995-97	722-515AP		722-515AM	35-503
462	1986	722-2504		722-2504	35-505
467-532	1985-95	722-2502		722-2502	35-505
494	1996-00	722-2505AP		722-2505AM	35-503
500	2003	722-2505AP		722-2505AM	35-503
521-532-536	1983-99	722-2505		722-2505	35-505
537-582-583	1983-99	722-2505		722-2505	35-505
500SS-600	2003-11	722-516AP		722-516AM	35-507
600, 600HO	1999-07	722-2510		722-2509	35-507
500SSXP-600	2008-10	722-2510		722-2509	35-507
600 HO SDI	2004-11	722-2510		722-2509	35-507
600 HO E-Tec	2004-11	722-2510		722-2509	35-507
617-643	1991-92	722-2505		722-2505	35-505
670	1993-99	722-2507		722-2506	35-507
700	1999-00	722-2507		722-2506	35-507
700	2001-02	722-2510		722-2509	35-507
800 HO, SDI	2000-06	722-2510		722-2509	35-507
800 RPTEK	2007-11	722-2520		722-2520	-
1000 SDI	2005-07	722-2518		722-2518	-
<b>3-cyl L/C</b>					
600-700	1996-98	722-2519	722-2519	722-2519	35-503
700	1999-00	722-2519	722-2519	722-2519	35-503
779	1993-96	722-2512	722-2511	722-2511	35-505
809	1997-03	722-2512	722-2511	722-2511	35-505

## Fett; vevaxel

**35-900** Fett 300 g

**35-901** Fett 50 g

Bör användas när MAG och / eller PTO lager är ett slutet utrymme



# Vevstake Rotax mått



P/N	längd C-C	övr dia	ne dia	up bre	ne bre	pin dia	pin längd	övre nållager	nedre nållager
722-2500	115	22	30	13	13	24	48	18x22x22	24x30x13
722-2503	115	22	30	15	15	24	47	18x22x22	24x30x15
722-2504	120	22	30	15	15	24	48	18x22x22	24x30x15
722-2505	125	22	31	17	17	24	52	18x22x22	24x31x17
722-2505AP	125	22	30	17	17	24	53	18x22x22	24x30x17
722-2505AM	125	22	30	17	17	24	55	18x22x22	24x30x17
722-2506	132	25	31	17	17	24	53	20x24x23	24x31x17
722-2507	132	25	31	17	17	24	55	20x24x23	24x31x17
722-2509	132	25	35	18	18	27	53	20x25x23	27x35x18
722-2510	132	25	35	18	18	27	55	20x25x23	27x35x18
722-2515	125	25	31	20	17	24	50	20x25x23	24x31x17
722-2518	144,5	29	40	23	23	30	64,80	24x29x23,4	30x40x23
722-2519	120	23	31	17	17	25	52/57	18x22x22	25x31x17
722-2520	132	27	40	20	20	30	57	22x24x24,8	30x40x20
722-516AP	125	25	30	17	17	24	55	18x22x22	24x30x17
722-516AM	125	25	30	17	17	24	53	18x22x22	24x30x17

## Nållager

P/N	mått	för kolvbult
35-502	16 x 21 x 20	692,696,
35-503	18 x 23 x 22	601,691,693,694,695,699,774,781,782,707,710, 711, 712,713,715,718,719,727,
35-505	18 x 22 x 22	740,741,742,746,747,748,750,751,752,758,759, 760,761,762,763,772,780,800,801,803,804,806, 807,810, 811,812,813,814,815
35-507	20 x 25 x 22,8	776, 778, 783, 785
35-513	16 x 20 x 20	706,708,670,
35-514	15 x 19 x 20	745,
35-520	18 x 23 x 21	700,702,703,704,705,
35-521	20 x 25 x 24	808, 816,817,818,825,826
35-522	16 x 20 x 22,5	689,802,
35-523	20 x 26 x 24	602,679,681,682,683,684,687,
35-524	20 x 24 x 22,7	773,779,
35-525	16 x 20 x 21,7	685,709,714,716,717,
35-526	22 x 27 x 25	730,
35-415R	21 x 27 x 24,7	09-7023 800R

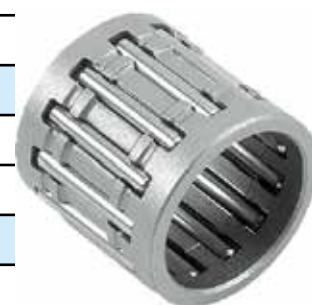

# Vevstake

## Polaris Vevstake



2-cyl F/C					
cc	år	PTO	Mitten	MAG	nållager
440-500	alla	724-2513		724-2512	35-503
550	2004-	724-2516		724-2516	35-503
2-cyl L/C					
440	1993-97	724-2513		724-2512	35-503
500	1993-11	724-2513		724-2512	35-503
500-600	1998-09	724-2517		724-2517	35-507
600-700	1997-01	010-535		010-535	-
800	2000-05	010-538		010-538	35-526

## Yamaha Vevstake

2-cyl F/C					
<b>535-540</b>	1979-06	010-523		010-523	35-521
2-sylinder L/C					
500-570-600	1987-96	010-525		010-525	35-507
500-600	1997-	010-525		010-525	35-507

## Arctic Cat Vevstake

2-cyl L/C			3-cyl L/C		
600 Carb	2004-06	3007-530		3007-530	b1074
600-700	2003-2010	3007-530		3007-530	
FF, CF 800	2007-2011	3007-530		3007-530	
800-900, ZR900	2001-2008	721-2500		721-2500	
M1000, F1000	2007-2011	3007-261		3007-261	
<b>Thunder 1000</b>	<b>2000-2002</b>	<b>3007-530</b>	<b>3007-530</b>	<b>3007-530</b>	

## Connection rods, mått, Polaris, Yamaha, Arctic Cat

P/N	Längd C-C	övr dia	ned dia	övr bredd	ned bredd	kolvb. dia.	kolvb. längd	övre nållager	nedre nållager
<b>724-2510</b>	<b>112</b>	<b>20</b>	<b>32</b>	<b>16</b>	<b>16</b>	<b>24,3</b>	<b>49</b>	<b>16x20x22</b>	<b>24,3x32,3x16</b>
<b>724-2512</b>	<b>112</b>	<b>23</b>	<b>32</b>	<b>16</b>	<b>16</b>	<b>24,3</b>	<b>56</b>	<b>18x23x22</b>	<b>24,3x32,3x16</b>
<b>724-2513</b>	<b>112</b>	<b>23</b>	<b>32</b>	<b>16</b>	<b>16</b>	<b>24,3</b>	<b>57</b>	<b>18x23x22</b>	<b>24,3x32,3x16</b>
<b>724-2516</b>	<b>120</b>	<b>23</b>	<b>32,3</b>	<b>16</b>	<b>16</b>	<b>24,3</b>	<b>57</b>	<b>18x23x22</b>	<b>24,3x32,3x16</b>
<b>724-2517</b>	<b>128</b>	<b>25</b>	<b>35</b>	<b>17</b>	<b>17</b>	<b>28</b>	<b>/</b>	<b>20x25x23</b>	<b>28x35x17</b>
<b>010-535</b>	<b>125</b>	<b>25</b>	<b>35</b>	<b>16</b>	<b>16</b>	<b>28</b>	<b>60</b>	<b>20x25x22</b>	<b>28x35x16</b>
<b>010-538</b>	<b>136</b>	<b>27</b>	<b>35</b>	<b>18</b>	<b>18</b>	<b>27</b>	<b>60</b>	<b>22x27x25</b>	<b>27x35x18</b>
<b>010-523</b>	<b>120</b>	<b>25</b>	<b>31</b>	<b>20</b>	<b>20</b>	<b>24</b>	<b>59</b>	<b>20x25x24</b>	<b>24x31x20</b>
<b>010-525</b>	<b>125</b>	<b>25</b>	<b>32</b>	<b>20</b>	<b>20</b>	<b>25</b>	<b>60</b>	<b>20x25x24</b>	<b>25x32x20</b>
<b>721-2500</b>	<b>146,5</b>	<b>25</b>	<b>39</b>	<b>22</b>	<b>22</b>	<b>30</b>	<b>/</b>	<b>24x29x23,8</b>	<b>30x39x22</b>
<b>3007-530</b>									
<b>3007-261</b>									



Kolven	Borring mm		Motor typ	P-sats	Packbox	Nållager	Taiwan
<b>09-7048</b>	Dia. 65,00	<b>2</b>	<b>453 ( 440 )</b>	710-258	55205	35-505	N/A
Lynx Racing 440 1998-04, Lynx Rave 440 2005-06							
<b>09-7045</b>	Dia. 69,50	<b>2</b>	<b>494 Rave</b>	710-212	55190	35-505	09-780
<b>09-7045-050</b>	Dia. 70,00		Kompressionshöjd 32,50 mm				
<b>09-7045-100</b>	Dia. 70,50		XR 500LC 2000, Ranger LCE 2001-02				
Cobra Ultra 1996, Glx 5900 LC 1996-99, Enduro 500 1997-99, Lynx ST 500 2002							
Enduro 500 1997-99, G-Touring 500 1998-00							
<b>09-7028</b>	Dia. 69,50	<b>2</b>	<b>493 Rave</b>	710-256	55205	35-505	<b>08-784</b>
<b>09-7028-050</b>	Dia. 71,00		Kompressionshöjd 30,50 mm				
<b>09-7028-100</b>	Dia. 71,50						
Lynx 5900 ST 2000, Enduro 500 2001-05, Gr Tour. 50 2001-02, Enduro 500RER -02							
<b>09-7047</b>	Dia. 76,00	<b>2</b>	<b>593 Rave</b>	710-259	55216	35-507	09-785
<b>09-7047-050</b>	Dia. 76,50		ST 600 2002-07, GR Tour. 600 2001-02,				
<b>09-7047-100</b>	Dia. 77,00		Enduro 600RER 2002, Ranger LCE 2003				
Enduro 600 SP 2000-02, Super Touring 600 2001-2003, Lynx 5900 ST 2001							
Ranger 600 2004-06, Adventure 600 2006, Rave 600 2006-							
<b>09-7053</b>	Dia. 72,00	<b>2</b>	<b>593 Rave RS</b>	710-278	55204	35-507	N/A
Lynx Rave 600 RS 2008-							
<b>09-7021</b>	Dia. 72,00	<b>2</b>	<b>600 SDI, HO</b>	710-278	55204	35-507	06-776
			<b>600 E-Tek</b>	710-303	55230		
Enduro 600SP 2003-04, Enduro 600 HO SDi 2004-05, Sport Touring 600 2003-05							
Sport Tourer 600 2003-05, Adventure 600 SDi 2006-08, Rave 600 SDi 2006-08							
XTRim 600 SDi 2006-08, Yeti 600 SDi 2006-08, Rave Re, SC 600 SDi 2007-08							
Gr Tourer 600 SDi 2009-2010, Rave E-Tec 600 2009-2012, XTRim 600 E-Tec 2011-12							
Commander 600 E-Tec 2012-13, XTRim Commander 600 E 2009-2011							
49 Ranger 600 E-Tec 2011							
<b>09-7056</b>	Dia. 78,00	<b>2</b>	<b>670</b> 93-94	710-197	55105	35-524	09-773
<b>09-7056-050</b>	Dia. 78,50		<b>670</b> 95-96	710-293	55190		
<b>09-7056-100</b>	Dia. 79,00		<b>670</b> 97-00	710-215	55190		
Rave 670 1994-97, Snow Cross 1996, Grand Touring 1997, Rave Big Pipe 1998-99							
Grand Touring Royal 1998-99, Rave Special 2000, G-Touring 700 2000.							
<b>09-7049</b>	Dia. 78,00	<b>2</b>	<b>693</b> 2000-02	710-255	55204	35-507	09-783
<b>09-7049-050</b>	Dia. 78,50		<b>693</b> 2003-04	710-255	55217		
<b>09-7049-100</b>	Dia. 79,00						
Super Touring 700 2001-02, Enduro 700 2001-02, Enduro 700 RER 2002							
<b>09-7022</b>	Dia. 82,00	<b>2</b>	<b>793</b> 2003-07	710-261	55217	35-507	09-778
<b>09-7022-050</b>	Dia. 82,50		<b>793</b> 2000-02	710-261	55204		
<b>09-7022-100</b>	Dia. 83,00		Ranger Mountain 2003-04, XTRim 800 PTek 2006-07				
Rave 800 2001-04, Rave 800 SDi 2005, RC 800 PTek 2006-07, Enduro 800 2001-02							
Super Touring 800 2002, Sport Touring 800 2003-04, Adventure 800 2005							

## Lynx - Rotax 1996-2014 Wössner Smidda Kolvar



Kolven	Borring mm		Motortyp	P-sats	Packbox	Nållager	Taiwan
<b>09-7023</b>	Dia. 82,00	<b>2</b>	<b>800 R</b>	710-302	55229	35-415R	N/A
<b>09-7023-050</b>	Dia. 82,50		<b>800 R E-Tek</b>	710-312	55229		
<b>09-7023-100</b>	Dia. 83,00						
<b>09-7023-300</b>	Dia. 85,00		Boondocker 800R E-Tec 12-13, Rave 800R E-Tec 12-13				
Rave 800R 08-11, XTRim 800R 2008-2010, Boondocker 800R 2011, GLS 3300 2013							
<b>09-7046</b>	Dia. 76,00	<b>2</b>	<b>550 F/C</b>	710-277	55215	35-507	09-779
<b>09-7046-050</b>	Dia. 76,50						
<b>09-7046-100</b>	Dia. 77,00						
Enduro 550 F 2003-05, Rave 550 2006-2012, 550 SUV 2003, ST 550 2004-07							
Lynx 6900 2004-06, Ranger 550F 2003-09, Explorer 550F 2003-05, Forest Fox 2005							
XTRim 550 2006-2012, Adventure 550 2006-09, Yeti 2008-2011							
<b>08-6002</b>	Dia. 82,00	<b>2</b>	<b>Rotax 747 Z</b>	Seadoo 718 piston 1996			
<b>08-6002-050</b>	Dia. 82,50			Cylinder height 121,3 mm			
<b>08-6002-100</b>	Dia. 83,00						
<b>08-6001</b>	Dia. 82,00	<b>2</b>	<b>Rotax 747 Z</b>	Seadoo 780 piston, 1997-2000			
<b>08-6001-050</b>	Dia. 82,50			Cylinder height 123,4 mm			
<b>08-6001-096</b>	Dia. 82,96						
Lynx Racing 747 Z, 1996-2000. Motorerna modifierade av Totaltek. Ca. 65 motorer							

## Ski-doo - Rotax 1996-2014 Wössner Smidda Kolvar



Kolven	Borring mm		Motortyp	P-sats	Packbox	Nållager	Taiwan
<b>09-7048</b>	Dia. 65,00	<b>2</b>	<b>453 ( 440 )</b>	710-258	55205	35-505	N/A
MXZ 440 LC X 1998-07							
<b>09-7045</b>	Dia. 69,50	<b>2</b>	<b>494 Rave</b>	710-212	55190	35-505	09-780
<b>09-7045-050</b>	Dia. 70,00		Kompressionshöjd 32,50 mm				
<b>09-7045-100</b>	Dia. 70,50		Scandik WT 1998-99, Formula 500 LC 2000				
Formula Mach Z 3-syl 779 Rave 1993-96, Grand Touring 500 1996-99, MXZ 500 98-99							
Formula SLS 1996, Summit 500 1997-99, Formula 500 DLX 1998-99							
<b>09-7028</b>	Dia. 69,50	<b>2</b>	<b>493 Rave</b>	710-258	55205	35-505	<b>08-784</b>
<b>09-7028-050</b>	Dia. 70,00		Kompressionshöjd 30,50 mm				
<b>09-7028-100</b>	Dia. 70,50						
MXZ 500 00-03, Touring 500 00-03, Scandik WT 2000							
<b>09-7047</b>	Dia. 76,00	<b>2</b>	<b>593 Rave</b>	710-259	55216	35-507	09-785
<b>09-7047-050</b>	Dia. 76,50		Summit 600 1999-01, MXZ 600 1999-02,				
<b>09-7047-100</b>	Dia. 77,00		Formula Z, DLX 600 2000-01				
Grand Touring 600 2000-03, Scandik 600 WT, SUV 2001-07, Legend GT 500 SS 2004							
MXZ 500 Rev SS 2004-06, GTX 500 SS 2005-07, TNT 2008-09, Summit 500 SS 2009							



Kolven	Borring mm		Motor typ	P-sats	Packbox	Nållager	Taiwan
<b>09-7053</b>	Dia. 72,00	<b>2</b>	<b>593 Rave RS</b>	710-278	55204	35-507	N/A
MXZ RS 600 2008-2013							
<b>09-7021</b>	Dia. 72,00	<b>2</b>	<b>600 SDI, HO</b>	710-278	55204	35-507	09-776
			<b>600 E-Tek</b>	710-303	55230		
Summit 600, RER, Adr. 2003-08, Renegade 600, X 2003-08, MXZ 600 REV-X 2003-06							
Legend GT 600 2004-, GTX 600 2005-08, Expedition YETI 600 SDi 2006-07							
MXZ 600 HO, RS-X 2007-08, Expedition 600 TUV 2008-, MXZ 600 E-Tec 2009-10							
Renegade 600 E-Tec 2009-12, Summit 600 E-Tec Everest, SP 2009-12							
Expedition 600 SDi, LE 2010-12, Grand Touring LE 2012-							
<b>09-7056</b>	Dia. 78,00	<b>2</b>	<b>670 93-94</b>	710-197	55105	35-524	09-773
<b>09-7056-050</b>	Dia. 78,50		<b>670 95-96</b>	710-293	55190		
<b>09-7056-100</b>	Dia. 79,00		<b>670 97-00</b>	710-215	55190		
Mach I X 93, Mach I 93-96, MXZ 670 96-98, Grand Touring SE 94-96, Formula SS 95-96							
Formula Z 670 98-99, Summit 670 96-99							
<b>09-7049</b>	Dia. 78,00	<b>2</b>	<b>693 2000-02</b>	710-255	55204	35-507	09-783
<b>09-7049-050</b>	Dia. 78,50		<b>693 2003-04</b>	710-255	55217		
<b>09-7049-100</b>	Dia. 79,00						
Grand Touring 700 2001-, Renegade 700 2002							
Summit 700 2000-01, Formula DLX 700 2000-01, MXZ 700 2001							
<b>09-7022</b>	Dia. 82,00	<b>2</b>	<b>793 2003-07</b>	710-261	55217	35-507	09-778
<b>09-7022-050</b>	Dia. 82,50		<b>793 2000-02</b>	710-261	55204		
<b>09-7022-100</b>	Dia. 83,00						
Summit 800HM, X, 162, Adr. 2000-07, MXZ 800X 2001-02, Renegade 800X 2002-07							
Grand Touring 800 2002-03, MXZ 800 REV-X 2003-07, Legend GT 800, GTX 800 05-07							
<b>09-7023</b>	Dia. 82,00	<b>2</b>	<b>800 R</b>	710-302	55229	35-415R	N/A
<b>09-7023-050</b>	Dia. 82,50		<b>800 R E-Tek</b>	710-312	55229		
<b>09-7023-100</b>	Dia. 83,00						
<b>09-7023-300</b>	Dia. 85,00						
MXZ 800 R X 2008-10, Renegade 800 X-XP 2008-10, Summit 800 X-XP 2008-10							
<b>09-7046</b>	Dia. 76,00	<b>2</b>	<b>550 F/C</b>	710-277	55215	35-507	09-779
<b>09-7046-050</b>	Dia. 76,50						
<b>09-7046-100</b>	Dia. 77,00						
Summit 550F 2003-08, MXZ 550 F, X 2003-09, Grand Touring 550F 2003							
Legend GT 550F 2004, Scandik WT 550, SUV 2003-09, Alpine IV 2004-05							
GTX 550F 2005-09, Freestyle, Back Country 2006-08, Tundra 2006							
Expedition Sport 2007, Scandik WT 600 2007, TNT 550 F 2010-12							
Renegade 550 Sport 2010-12, Grand Touring Sport 550F 10-12, Scandik Tundra 10-12							
<b>09-7050</b>	Dia. 88,00	<b>2</b>	<b>Rotax 997</b>	710-289	55226	3008-583	N/A
Renegade 1000 X 2006-07, Mach Z 1000 2006-07, Summit 1000 HM 151, 162, 06-07							

Kolven	Borrning mm		Motortyp	P-sats	Packbox	Nållager	Taiwan
<b>09-7040</b>	Dia. 70,50	<b>2</b>	<b>500</b> 99-01	710-237	55194	35-521	09-720
<b>09-7040-050</b>	Dia. 71,00		<b>500</b> 02-07	710-250	55194		
XC 500, SP, X, 1999-03, 500 SKS, E, 00-01, XC 500 SP RACE 2004-06							
<b>09-7015</b>	Dia. 73,00	<b>2</b>	<b>544</b> 99-03	710-238	55196	35-503	09-727
<b>09-7015-050</b>	Dia. 73,50		<b>544</b> 03-13	710-286	55218		
<b>09-7015-100</b>	Dia. 74,00		Sport Touring, E, 2000-04, Trail Touring, DLX 2000-09, 550 Super Sport Edge 2001-02, PRO X 550 2004, RMK 550 2004-07				
IQ 550 SHIFT, LXT 2010-12, 550 Transport 2010-11, Super Sport, X, 1999-07							
<b>09-7016</b>	Dia. 74,50	<b>2</b>	<b>600</b>	710-230	55193	35-507	09-721
600 XC Special 1998-99							
<b>09-7017</b>	Dia. 77,25	<b>2</b>	<b>600</b> 00-06	710-251	55194	35-507	09-728
			<b>600</b> 07-09	710-297	55219		
			<b>CFI</b> 07-08	710-298	55225		
			<b>IQ</b> 08-12	710-305	55225		
HO IQ Touring CFI 2007-, XC 600 SP, EDGE 2000-07, 600 Classic, Touring 2001-06, XC 600 X M10 2002, PRO X 600 2003-04							
XC 600 SP X 2003-, RMK 600 2004-07, 600 Switchback 2004-07; All 600cc 00-13							
XC 600 XP RACE 2005-, HO Fusion, IQ 600 2006-07, HO IQ 600 CFI 2007-							
<b>09-7055</b>	Dia. 73,80	<b>2</b>	<b>600</b> 08-13	710-305	55225		N/A
IQ Racer 600							
<b>09-7018</b>	Dia. 81,00	<b>2</b>	<b>700</b> 99-01	710-231	55193	35-507	09-722
<b>09-7018-050</b>	Dia. 81,50		<b>700</b> 02-05	710-265	55193		
<b>09-7018-100</b>	Dia. 82,00		XC 700, SP 1999-00, 700 SKS 1999-00,				
<b>09-7018-300</b>	Dia. 84,00		RMK 700 1997-00, INDY XC 700 1998-03				
INDY 700 SKS 1998-03, PRO X, X2 700 2003-05, Switchback 700 2004-05							
<b>09-7031</b>	Dia. 81,00	<b>2</b>		710-298	55225	35-526	N/A
Dragon 700 2007-08, RMK 700 2007-2010							
<b>09-7041</b>	77,50		<b>700</b>	710-288	55214	35-526	N/A
<b>09-7041-100</b>	78,50						
RMK 700, 2006, Fusion 700 2006,							
<b>09-7043</b>	Dia. 72,00	<b>3</b>	<b>794</b>	710-254	55186	35-503	09-731
XCR 800 3-syl 1999-00							
<b>09-7019</b>	Dia. 85,00	<b>2</b>	<b>794</b>	710-252	55193	35-526	09-730
<b>09-7019-050</b>	Dia. 85,50		800 RMK 2000-, XC 800 SP EDGE, X, 2001-02,				
<b>09-7019-100</b>	Dia. 86,00		PRO X 800 2003-04				
800 Touring 2004-05, 800 Switchback 2005-08.							
<b>09-7044</b>	Dia. 85,00	<b>2</b>	<b>800</b> 08-09	710-306	55225	35-526	N/A
			<b>800</b> 10-12	710-310	55225		
Dragon 800, Assault 800 All, RMK 800, RUSH 800 <b>2009-</b>							
<b>09-7020</b>	Dia. 83,00	<b>2</b>	<b>900</b>	710-282	22214	35-526	N/A
<b>09-7020-100</b>	Dia. 84,00		900 RMK 05-06, Fusion 900 05-06, Switchback 900 2006				

## Yamaha 1996-2014 Wössner Smidda Kolvar

Kolven	Borrning mm		Motortyp	P-sats	Packbox	Nållager	Taiwan
<b>09-7024</b>	Dia. 68,00	<b>2</b>	<b>500 L/C</b>	710-200	55188	35-521	09-829
Venture 500 1998-01, VMax 500 XTC, DX 1998-, SRX 500 1999, SX 500 R 2000-01							
<b>09-7057</b>							
<b>09-7057-050</b>							
<b>09-7057-100</b>							
Mountain Lite 97-99, Phazer 84-01, Venture 91-03, XL-V 91-93							
<b>09-7058</b>	Dia. 73,00	<b>2</b>	<b>535</b>		55133	35-521	09-808
<b>09-7058-050</b>	Dia. 73,50		SRV-90	710-167			
<b>09-7058-100</b>	Dia. 74,00		VK 88-05	710-182			
EC540 79-84, SR540 80-91, XL540 85-90, VK540 1988-2007, Viking III -2014							
<b>09-7025</b>	Dia. 74,80	<b>2</b>	<b>598 L/C</b>	710-201	55188	35-521	09-826
VMax 600 DX, ST, XT, XTC 1994-98, Mountain Max 600 1996-99, Venture 600 97-98							
<b>09-7051</b>	Dia. 65,00	<b>3</b>	<b>600 3-syl</b>	710-240	55198	35-507	09-830
SRX 600 1999, Venture 600 1999-04, VMax 600 DX 1999-00, SX 600 R 2000-02							
<b>09-7026</b>	Dia. 70,50	<b>3</b>	<b>698 3-syl</b>	710-241	55198	35-507	09-828
Mountain Max 700 1996-02, VMax 700 XTC, DX 1998-01, Venture 700 1998-03							
SX 700 R 2000-01							
<b>09-7027</b>	Dia. 69,00	<b>3</b>	<b>696 3-syl</b>	710-246	55199	35-507	09-831
<b>09-7027-100</b>	Dia. 70,00						
<b>09-7027-400</b>	Dia. 73,00		VMax 700 SX 1997,				
Mountain Max 700 1999, Mountain SRX 700 1998-99, SRX 700 1998-99							
<b>09-7052</b>	Dia. 69,00	<b>3</b>	<b>700 3-syl</b>	710-269	55199	35-507	N/A
<b>09-7052-100</b>	Dia. 70,00		Venture 700 2004-				
SRX 700 2000-02, SXViper 700, ER 2002-04, SXViper Mountain 2003-04							
<b>09-7501</b>	Dia. 77,00	<b>2</b>	<b>499</b>	711-299	N/A	35-507	N/A
Phazer GT 2007, Phazer Mountain Lite 2007, Phazer FX, MTX, FTX, R-TX 2007-10, Phazer Multipurpose 2007, Venture Multipurpose 2008-10, Venture Lite 2008-10							
<b>09-7502</b>	Dia. 74,00	<b>3</b>		711-314	N/A	N/A	N/A
RX-1 Mountain 2003-04, RX-1 ER 2003-06, RX-1 2003-, RX Warrior 2004-06							
<b>09-7503</b>	Dia. 75,00						
RX-1 Mountain 2003-04, RX-1 ER 2003-06, RX-1 2003-, RX Warrior 2004-06							
<b>09-7504</b>	Dia. 74,00						
RX-1 Mountain 2003-04, RX-1 ER 2003-06, RX-1 2003-, RX Warrior 2004-06							
<b>09-7505</b>	Dia. 75,00						
RX-1 Mountain 2003-04, RX-1 ER 2003-06, RX-1 2003-, RX Warrior 2004-06							

## Arctic Cat 1987-2014 Wössner Smidda Kolvar

Kolven	Borrning mm		Motortyp	P-sats	Packbox	Nållager	Taiwan
<b>09-7001</b>	Dia. 65,00	<b>2</b>	<b>431 F/C</b>	wwwpage	55109	35-502	09-696
Jag AFS, 440, 87-99, S. Jag 87-97, Z440 95-98, Bearcat 440,93-00, Panther 440 -01							
<b>09-7002</b>	Dia. 68,00	<b>2</b>	<b>435 L/C</b>	wwwpage	wwwpage	35-502	09-695
Pantera 440 1985-90, El Tigre 5000 440 1987-89							

Kolven	Borring mm		Motortyp	P-sats	Packbox	Nållager	Taiwan
<b>09-7034</b>	Dia. 66,50	<b>2</b>	<b>440 L/C</b>	710-273	55203	N/A	N/A
ZL 440 97-00, Jag 440 96, Cougar 91-94, Cheetah Tour. 91-94, Z 440 ESR 03-04							
<b>09-7004</b>	Dia. 71,00	<b>2</b>	<b>497 L/C</b>	wwwpage	wwwpage	35-xxx	35-605
ZRI 500 1998-2000, Powder Special 500 EFI 2000							
<b>09-7035</b>	Dia. 71,00	<b>2</b>	<b>499 L/C</b>	wwwpage	55222	35-xxx	N/A
ZR 500 01-02, Sabercat 500, EFI, LX 03-06, M5, M5 EFI 05-06, F5 EFI, F5 EFI LXR 2007-10, CF EFI 07-09, Snopro 500 2010-13, T500 08-09							
<b>09-7005</b>	Dia. 73,40	<b>2</b>	<b>550 L/C</b>	710-189	55176	35-523	09-687
Bearcat 550 -95-2002, EXT 550 1992-96, ZL 550 2000-03							
Pantera 550 1991-2005, Panther 550 1997-2001, Prowler 2-up 1995							
<b>09-7037</b>	Dia. 75,40	<b>2</b>	<b>581 L/C</b>	710-189	55176	35-523	09-681
Prowler 580 1996, EXT 580 1993-98, ZR 580 1993-97, Pantera 580 1996-98							
<b>09-7006</b>	Dia. 66,50	<b>3</b>	<b>594 3-syl</b>	710-216	55176	35-503	09-601
Triple Touring 600 1999-2000, ZRT 600 1996-2000							
<b>09-7007</b>	Dia. 78,00	<b>2</b>	<b>599 L/C</b>	710-227	55176	N/A	N/A
<b>09-7007-050</b>	Dia.		Powder Special 600 1998-2000, ZR 600 1998-99				
<b>09-7008</b>	Dia. 78,00	<b>2</b>	<b>599 L/C</b>	710-249	55203	N/A	35-609
Mountain Cat 600 2001-04, Pantera 600 EFI 2002-05							
Powder Special 600 EFI, ZR / ZL 600 EFI 2000-03							
<b>09-7054</b>	Dia. 73,70	<b>2</b>	<b>600 L/C</b>	710-304	55223	N/A	N/A
Sabercat 2004-, F6 2004- , M6 2004- ,Sno Pro 600 2009-13							
<b>09-7009</b>	Dia. 79,70	<b>2</b>	<b>698 L/C</b>	710-275	55221	35-526	09-657
Sabercat 700 EFI 2004-06, Crossfire7 2006, F7 Firecat 2004-06, M7 2005-06							
<b>09-7010</b>	Dia. 81,00	<b>2</b>	<b>699 L/C</b>	www.sida	55173	35-523	09-682
<b>09-7010-050</b>	Dia. 81,50		Powder Special 700 99-00, ZR 700 99-00,				
<b>09-7010-500</b>	Dia. 86,00		Wildcat 700 M.C, EFI 91-96, ZL 700 -00				
<b>09-7011</b>	Dia. 81,00	<b>2</b>	<b>785 L/C</b>	710-262	55207	N/A	09-611
<b>09-7011-500</b>	Dia. 86,00						
ZL 800 EFI, ESR 02-03, ZR 800 01-03, Mt Cat 800, EFI 01-04, Pantera 800 EFI 02-04							
<b>09-7012</b>	Dia. 72,00	<b>3</b>	<b>794 3-syl</b>	710-287	55182	35-523	09-602
ZRT 800 1995-2001, Pantera 800 1998-99, Thundercat M.C 1996							
<b>09-7038</b>	Dia. 85,00	<b>2</b>	<b>784 L/C</b>	710-285	55223	N/A	N/A
F8 EFI Snopro 07-09, M8 Snopro 09-, CF 8 Snopro 09-, Crossfire 800 07-08, 794cc-2013							
<b>09-7030</b>	Dia. 85,00	<b>2</b>	<b>862 L/C</b>	710-262	55207	N/A	
Mt Cat 900 03-04, King Cat 900, EFI, Snopro 04-06, ZR 900, EFI 03-06, ZR 900							
<b>09-7039</b>	Dia. 76,50	<b>3</b>	<b>895 3-syl</b>	710-193	55173	N/A	N/A
<b>09-7039-400</b>	Dia. 80,50						
<b>09-7039-450</b>	Dia. 81,00		Thundercat 900 1993-97, Thundercat 900 1993-97				
<b>09-7013</b>	Dia. 81,00	<b>3</b>	<b>993 3-syl</b>	710-193	55182	N/A	N/A
<b>09-7012-400</b>	Dia. 85,00						
Thunder Cat 1000 M.C 98-02, Mountain Cat 1000 01-02, Pantera 1000 00-01							
<b>09-7014</b>	Dia. 90,31	<b>2</b>	<b>1000 L/C</b>	710-296	55224	N/A	N/A
Crossfire 1000, F1000, M1000 2007-2009							

## Hi-Performance Smidda Kolvar Seadoo-Jet Ski

<b>Arctic Cat</b>	kolv p/n	cyl	cc	Dia.	gasket, full set
SX-R800 03-11	08-6010	2	782	82,00	
JS900, ZXI900 95-97,	08-6009	3	891	73,00	08-611502
STX900 96-06, STS900 01-02					
ZXI1100 90-03, STX110097-03	08-6007	3	1071	80,00	
Överdimension varje 0,5 mm					
<b>Ski-doo, Sea-doo</b>					
XP/GTI/HX/SPX/GTS/GS/GSI 95-03	08-6002	2	718	82,00	08-611204
Överdimension 0,50 mm	08-6002-050				
Överdimension 1,00 mm	08-6002-100				
XP/SPX/GSX/GTX/GTX/GTI 97-03	08-6001	2	780	82,00	
Överdimension 0,50 mm	08-6001-050		800 Carbu		08-611205
Överdimension 0,96 mm	08-6001-096		800 RFI new		08-611209
GSX-LTD/XP-LTD/GTX-LTD 97-05	08-6011	2	951	88,00	
LRV/RX950 97-05, Sporster950 00-03, VSP950 99-03			951 Carbu		08-611206
Överdimension 0,50 mm	08-6011-050		951 DI		08-611210
Överdimension 1,00 mm	08-6011-100				
<b>Polaris</b>					
SL 700, Virage, 96-04	010-832	2	700	81,00	08-611804
SL 750, SLT, MSX110-150 93-04	010-830	3	750	69,75	08-611802
Octane, Virage 777, 02-04	010-835	3	800	84,00	08-611807
SL 780, SLT 780, 96-97	010-834	3	780	71,50	08-611803
SL 1050, SLX, SLTX, 96-98	010-832	3	1050	81,00	
Genesis 1200, 99-04	010-835	3	1200	84,00	08-611809
Genesis 1200, 02-04	010-835-07	3	1200	85,00	08-611812
<b>Kawasaki</b>					
JS750 SS, SSXi, ST, SX, XIR 92-95	08-6006	3	750	80,00	08-611407
SX-R800 03-11	08-6010	2	800	82,00	08-611409
JS 900, ZXI, STS, STX 95-06	08-6009	3	900	73,00	08-611404
ZXI 1000, STX, Ultra 96-04	08-6007	3	1100	80,00	08-611405
Ultra 150 STX-R, 95-05		3	1200	80,00	08-611411
<b>Yamaha</b>					
Super Jet 700 93-10, Wave Runner	08-6005	2	701	81,00	08-611605
Wave Blaster 700, Wave Venture XL700 02, 700 mallit 93-98					
Wave Runner 1100 95-97	08-6005	3	1100	81,00	08-611604
Överdimension 0,50 mm	08-6005-050				
Överdimension 1,00 mm	08-6005-100				
GP800R 98-05, XL, XLT800 00-04	08-6004	2	800	79,90	08-611607
Överdimension 0,50 mm	08-6004-050				
Överdimension 1,00 mm	08-6004-100				
XL, XLT 1200 98-05	08-6004DD	3	1200	79,93	08-611608
GP 1300R 03-08	08-6003	3	1300	83,90	08-HLYG1300

# Nicasil renoverade originalcylindrar

Den gamla cylindern behövs alltid:

- får inte ha en avbruten nedre foderdel
- får inte vara portad
- får inte vara svetsad

Livstids garanti mot fabrikationsfel



Rotax	del no:	år	modell
60-440A	923720	99-06	440 MXZ X 440 Racing
60-550A		03-13	550 F/C, obs: 0,50 mm öd, t.ex. Wössner
60-600A	613710	03-06	600 HO motortyp
	613712		
	613714		
60-600B	613940	04-07	600 HO SDI motortyp
	613942		
	613944		
60-600C	623262	2009	600 E-Tek,
60-600C	263262	2010	600 E-Tek; Ett hål i RAVE ventilen för smörjning
60-600E	623263	2010-	600 E-Tek
60-600F	623480	08-10	600 RS
60-600FA	623481	2011	600 RS
60-600FF	623482	2012	600 RS
60-700B	923691	2000	700 tapp 8 mm
60-700C	923692	00-04	700 tapp 10 mm
	923693		
	923695		
60-800A	923813	03-04	800 SE SDI, Legend, Grand Touring
60-800B	923810	00-04	800 MXZ, Legend 800, Summit 800 HO
	923811		
	923815		
	923817		
60-800D	613852	05-07	800 HO PTEK, Renegade, Summit
60-800G	613852	05-07	800 HO, Techmaster gjutning
60-800E	413041	07-13	ersätter alla följande typer:
monobloc	623240	07-13	800R, monobloc MXZ X 800 R
	623241	07-13	avgasbultar, använd 8 mm bultar
	623242	07-13	800R, PTEK, monobloc
	623246	07-13	800R, PTEK, Techmaster, 8 mm avgasbultar
	623249	07-13	800 R E-Tek, monobloc ( 623246 )
	413042	07-13	
	413046	07-13	
60-1000A	613744	06-07	Mach Z 1000 SDi
60-1000B	613746	06-07	Summit 1000 SDi, MXZ Renegade 1000



# Nicasil renoverade originalcylindrar

<b>Polaris</b>	<b>del no:</b>	<b>år:</b>	<b>fabrikat modell</b>
61-440B	3021604	05-07	440, IQ440
61-440C	3021304	02-04	440, PRO X 440
61-500B	3021185	2001	500, XC SP
61-500C	3021256	2002	500, XC SP, M10
61-500D	3021334	03-07	500-600, XC SP, EDGE
61-550A	3089934	07-11	550, Edge, 550 IQ, Supersport, Trail
61-600D	3021333	03-06	600, PRO X
61-600E	3021542	06-09	600, HO, Fusion, RMK, IQ, RR
61-600G	3021718	07-13	600, HO IQ Cleanfire
61-600R	3022206	10-13	600, Rush, Widetrack IQ
61-600S	3022305	12-13	600, RMK, Rush, Switchback
61-700A	3021866	08-11	600-700, RMK, Dragon, Switchback
61-700B	3021220	97-98	700 RMK, SKS, XP
61-700C	3021824	99-01	700 RMK, SKS, XC, XC SP, XC DLX, Classic
61-700K	3021367	04-05	700, Pro X, XC SP, XC Edge
61-700R	3021767	07-08	700, RMK, Dragon, Cleanfire
61-800A	3022201	2010	800 Dragon, Assault, Switchback, IQ
61-800B	3021064	00-01	800, RMK, XC SP
61-800D	3021339	03-05	800 Pro X, RMK, XC Edge, XC SP, Pro XC
61-800H	3021843	08-09	800, monoblock, Assault RMK, 800 Dragon SP, IQ
61-800R	3022205	2011	800, monoblock, Assault, Rush
61-800S	3022352	2012	800, monoblock Assault, Rush, RMK
61-800T	3022449	2013	800, monoblock Assault, Rush, RMK
61-900A	3021563	2006	900, Fusion



## Nicasil renoverade cylindrar

Den gamla cylindern behövs alltid:

- får inte ha en avbruten nedre foderdel
- får inte vara portad
- får inte vara svetsad

Livstids garanti mot fabriktionsfel



<b>Arctic Cat</b>			
63-370A	3005453	99-08	Z370, Panther 370
63-500A	3006422	03-06	500, Firecat 500, SP
63-570A	3005999	02-11	570, Bearcat 570, Z570, Panther 570
	3007479		
63-600A	3005653	01-05	600, ZL-ZR 600 EFI, Pantera 600 Efi
63-600B	3006643	04-11	600, Firecat 600, Sabercat 600, M6 Efi
63-700B	3006492	03-06	700, CF 700, Firecat 700, Sabercat 700
63-800B	3007522	07-09	800, CF 800, F8 Efi, M8
63-800C	3007849	10-13	800, CF8, CF 8 Snopro, M8, F8 LXR
63-900A	3006696	04-06	900, ZR 900 Efi, King Cat 900, MC 900

# Seadoo; vevaxellager

Sea-Doo	år	PTO	Centre		MAG
587L/Cbaglabyr. eller T-Crank	88-96	6207NCR4 X 2	6206NCR4	6206NCR4	6206NCR4 x 2
650 L/C	93-96	6207NCR4 X 2	6206NCR4	6206NCR4	6206NCR4 X 2
717 L/C	95-05	6207PC4 X 2	6206PC4	6206PC4	6206PC4 X 2
787 L/C Big gear, 787 L/C	95-99	6306PC4, 6207PC4	6207PC4	6207PC4	6207PC4 X 2
951 L/C, 947 DI Big gear	98-05	6208PC4 x 2	6306PC4	6208PC4	6208PC4 X 2
<b>Arctic Cat</b>					
639, 640 L/C 2-cyl		6207PC4	6207GPC4	6207PC4	6207PC4
770 L/C 2-cyl		85B551A35mm	85B551A35mm	85B551A35mm	85B551A35mm
900, 1000, 1100 L/C 3-cyl		6209/1DRIN	6209/1DRIN x2	6209/1DRIN x2	6306/1DYRI
<b>Kawasaki</b>					
JS 440- JS 550	86-95	6206NRC4	6305NRC4	6305NRC4	6206NRC4
JS 650 gänga 18 mm	92-97	6306C4	6306C4	6306NRC4	6306C4
JS 750, JS 800, 2-cyl		6306NRC4	6306NRC4	6306NRC4	6306NRC4
JH 900 3-cyl		6307PC4	6207PC4 X 2	6207PC4 X 2	5207PC4
JH - JT 1100, JS 1200 3-cyl		6307PC4	6207PC4 X 2	6207PC4 X 2	5207PC4
<b>Polaris 3-cyl</b>					
700 L/C USA	97	6027C4 X 2	6207C4	6207NRC4	6207C4 X 2
800 L/C	02-04	6207C4 X 2	6207C4	6207NRC4	6207C4 X 2
650 - 750 - 780 L/C	92-97	6307GPC4	6207PC4 X 2	6207PC4 X 2	6207PC4 X 2
785 SP Svart motor		6307GPC4	6207PC4 X 2	6207PC4 X 2	6207PC4 X 2
900 - 1050 L/C USA	96-98	6207C4 X 2	6207C4 X 2	6207C4 X 2	6207C4 X 2
1200 L/C		6207C4 X 2	6207C4 X 2	6207C4 X 2	6207C4 X 2
<b>Yamaha</b>					
650 - 700 - 760		83A726-E	6207R9	6207R9	83B207
800 2-cyl		6308GPC4	6208PC4	6208PC4	5207PC4
1100 - 1200 3-cyl		83A726-E	6207R9 X 2	6207R9 X 2	83B207 S
1200 GR 3-cyl		6308GPC4	6208PC4 X 2	6208PC4 X 2	OEM

## Beställningsnummer mått

6206PC4	30 x 62 x 16	5207PC4	35 x 72 x 27	83A726-E	35 x 80 x 21
6206NRC4	30 x 62 x 16	6305NRC4	25 x 68 x 17	83B207	32 x 72 x 30
6207C4	35 x 72 x 17	6306/1DYRI	30 x 75 x 19	85B55135mm	35 x 75 x 17
6207PC4	35 x 72 x 17	6306C4	30 x 72 x 19	6209/1DRIN	45 x 90 x 19
6207R9	35 x 72 x 17	6306PC4	30 x 72 x 19	6308GPC4	40 x 90 x 23
6207NRC4	35 x 72 x 17	6307PC4	35 x 80 x 21		
6208PC4	40 x 80 x 18	6307GPC4	35 x 80 x 21		

## Vevaxeldel konsida, snöskotrar



**09-187 Rotax 503**

**09-1880 Rotax 670**

**09-1881 Rotax 800HO**

**09-1882 Rotax 500 + 600**

**09-1883 Rotax 700**

**09-1884 Rotax 800R**



**Polaris**

**09-241 Polaris XC500+XC600**

**09-185 Polaris XC800**

**09-186 Polaris XC700**

## Arctic Cat



07-100 01  
JAG 87-91, 0109-926

## Polaris:



07-100 05  
VM 38 SS, 3083171

## Rotax



07-100 10  
VM 34 rak



07-100 13  
SKID. VM 30, 32, 34 HD



07-100 22  
VM34,79-84, 570.1339.00

## Förgasargummi



VM 30, 32, 34 HD  
07-100 13



07-100 06  
VM 32, 34, HR, 3083306



07-100 11  
VM 34, 570.1262.00



07-100 20  
TUNDRA VM 34



07-100 23  
VM 40, 44, 570.038.200

## Yamaha



07-100 13  
VM 30, 32, 34 HD



07-100 13  
VM 30, 32, 34 HD



07-100 12  
VM 570.1261.00



07-10021 MX 85-92

Kolla vilken fögasargummi passar på din snöskoter på vår hemsida

[www.teolehtimaki.fi/  
varaosaluettelot](http://www.teolehtimaki.fi/varaosaluettelot)

Där hittar du alla andra delar som vi har till din snöskoter



## Snöskoter kolvar: Taiwan

- toppkvalitet, med kolvringar, kolvbult och låsringar  
- mos 2 ytbehandling

Nyheter för kommande säsong

09-650 Bearcat 570  
09-657 F7 Firecat  
09-776 Rotax 600 H.O, E-Tec  
09-778 Rotax 800 H.O.

Arctic Cat	Borrning	Motortyp	Packningsatts	Packbox	Nållager
<b>09-602</b>	72,00	<b>794 3-cyl</b>	710-193	09-55182	35-523
Pantera 800 1998-01 ZRT 800 1995-01					
<b>09-657</b>	79,70	<b>698 2-cyl</b>	710-275	09-55221	35-503
Crossfire 7 -06, F7 Firecat 2003-06, Sabercat 2004-06, M72005-06					
<b>09-682</b>	81,00	<b>699 2-cyl</b>	710-180; -91-96; 710-267; -97-01	09-55173	35-523
Wildcat 700 MC. EFI 1991-96, ZR 700 1995, ZL 700 2000, ZR 700 1999-00					
<b>09-684</b>	78,00	<b>650 2-cyl</b>	710-180	09-55175	35-523
Wildcat 650 1988-90, Mountain Cat 1990					
<b>09-601</b>	66,50	<b>594 3-cyl</b>	710-216	09-55176	35-503
EXT 600 Tr. 97-98 EXT 600 Triple Touring 1998 Powder EXT 600 1997-98 ZRT 600 1995-98					
<b>09-681</b>	75,40	<b>580 2-cyl</b>	710-189	09-55176	35-523
EXT 580 MC; EXT 580 EFI MC 1993-97; 580 Powder SP 1995-97; ZR 580 1993-97; Pantera 580 1995-97					
<b>09-650</b>	73,75	<b>565 F/C 2-cyl</b>	710-270	09-55212	35-503
Bearcat 570 2004-09, F570 08-, Mountain Cat 570 2002-, T570 2008-, Z570, LX, Panther 570 2002					
<b>09-683, 687</b>	73,40	<b>550 2-cyl</b>	710-189	09-55176	35-523
EXT special 1991-92 ; Pantera 550 2002-05, Panther 550 2000-01, ZL 550 ESR 2000-03; Bear Cat 550WT 2000-					
<b>09-679, 605</b>	71,00	<b>497 2-cyl</b>	710-227; -98-01; 710-266	09-55203	35-523
ZL 500 EFI 1998-01; ZR 500, ERSI 1998-01; Powder SP 500 EFI 1999-01					
<b>09-699</b>	72,00	<b>529 2-cyl</b>	710-063D	09-55112	35-503
Cheetah LC 1986-89; El Tigre 6000 1986-89; El Tigre EXT 1989-91; El Tigre Ext Mountain Cat 1990					
<b>09-691</b>	70,00	<b>500 2-cyl</b>	710-063E	09-55109	35-503
Cheetah FC, Cougar 1986-90					
<b>09-693</b>	70,00	<b>500 2-cyl</b>	710-063	09-55109	35-503
Panther 1986-88; Pantera el. 1980; Manx 2000S 1977-80, El Tigre 6000 LC 1980-85; El Tigre 5000 1977-81					
<b>09-694</b>	70,00	<b>500 L/C 2-cyl</b>	710-063C	09-55112	35-503
El Tigre 6000 LC 1980-85					
<b>09-689</b>	68,00	<b>440 2-cyl</b>			35-522
El Tigre 440 Z 1975-77; <b>Kawasaki Intriguer, Intruder, Invader; Drifter 440 1978-81</b>					
<b>09-695</b>	68,00	<b>440 2-cyl</b>	710-063A	09-55112	35-503
Panther 440 LC 1996; ZL 440 1997-99; Prowler 1990-94; Jag 440 LC; El Tigre 6000 LC 1978-79; Jag 4000 FC 80-81					
<b>09-696</b>	65,00	<b>431 2-cyl</b>	Tarkista netti	09-55109	09-502
Bearcat 440 95-01; Cheetah 440 -94; Panther 4000 FC 80-81; Trail Cat 4000 FC 80-81; Jag 4000 FC 1980-81					
Jag 440 Z 91-96; Panther DeLuxe 440 84-01; Z 440 ES 90-01; Super Jag 91-92; Jag 440 DeLuxe 88-99; Jag AFS LT					
<b>09-685</b>	60,00	<b>339 2-cyl</b>	710-032	09-55113	35-525
Panther, Puma, Cheetah, Pantera 1971-1975 Lynx II -74Jag 340 -75					
<b>09-692</b>	60,00	<b>339 2-cyl</b>	710-063B	09-55110	35-502
Bearcat 340 -95-01; Cheetah 340 -94; Jag 340 76-77, 87-90; Jag 3000 FA, FC 78-80; Jag Deluxe 1987-90					
Trail Cat 3000 FC 1980; Manx, Manx Deluxe 1991-93; Manx Mountain Cat 1992-93; Puma DeLuxe 1994-97					

<b>Skidoo, Lynx</b>	<b>Borning</b>	<b>Motortyp</b>	<b>Packningsats</b>	<b>Packbox</b>	<b>Nållager</b>
<b>09-778</b>	82,00	<b>793 HO, SDI</b>	710-302	09-55229	35-507
Skidoo, Lynx 800 HO, SDI mallit 2000-2007					
<b>09-782</b>	70,50	<b>809 3-cyl</b>	710-221 1997-2003	09-55181	35-505
Formula 700, Legend 700, MXZ 700 Summit 700 2000-2002					
<b>09-780</b>	69,50	<b>779 3-cyl</b>	710-222 3-syl	09-55181	35-505
<b>09-780-02</b>	70,00	<b>500 2 cyl</b>	710-212 2-syl	09-55190	35-505
MM: Mach Z 780 1993-97; MXZ 500 98-Scandic WT LC 1999-00; Summit 500 1996-99;					
<b>09-783</b>	78,00	<b>700 2-cyl</b>	710-255	09-55217	35-507
Formula 700, Legend 700, MXZ 700 Summit 700, 2000-02, Enduro 700 2001-02, Enduro 700 RER 2002					
<b>09-781</b>	70,00	<b>699 3-cyl</b>	710-222	09-55181	35-503
Rotax 700; F 3 700 1998-00; GT 700 1998-00; GT SE 1997-98; Mach 1 700 1997-00					
<b>09-773</b>	78,00	<b>669 2-cyl</b>	710-197 1993-94	09-55105	35-524
09-773-01			710-293 1995-95	09-55190	35-524
09-773-02			710-215 1996-00	09-55190	35-524
09-773-04					
Rotax 670; Mach 1 X 1993; Mach 1 1993-96; MXZ 670 1996-99; GT SE 1994-96;					
<b>09-776</b>	72,00	<b>600 E-Tek, Sdi</b>	710-303	09-55230	35-507
Rotax 600 HO RER, 600 E-Tec, 600 SDI					
<b>09-785</b>	76,00	<b>597 2-cyl</b>	710-259	09-55205 -02	35-507
09-785-02				09-55215 03-	
MM: Lynx 600 L/C modeller; Formula 600 1999-01; MXZ 600 1999-02; Scandik 600 WT L/C 2001-02					
<b>09-774</b>	64,50	<b>600 3-cyl</b>	710-213	09-55181	35-524
Formula III 600 1995-97					
<b>09-772</b>	76,00	<b>582 2-cyl</b>	710-178B 1988-92	09-55105	35-505
09-772-01		<b>582 2-cyl</b>	710-194 1993-96	09-55105	
09-772-02		<b>583 2-cyl</b>	710-178C 1993-96	09-55105	
09-772-04		<b>583 2-cyl</b>	710-214 1997-99	09-55105	
		<b>617 2-cyl</b>	710-178B Mach 1	09-55105	35-505
MM: Formula Plus, E, XTC,X 1992-93; F Plus EFI 1993-94; Summit 1994-96; Lynx mallit 582-583 koneella					
<b>09-762 left</b>	69,50	<b>635 2-cyl</b>	710-022X	09-55125	35-505
09-762-02					
09-762-04					
<b>09-763 right</b>	69,50	<b>635 2-cyl</b>	710-022X	09-55125	35-505
09-763-02					
09-763-04					
Alpine 640 1969-82; Nordic 640 1970-74; TNT 640 1971-72; Valmont 1971-72					
<b>09-779</b>	76,00	<b>550 F/C</b>	710-277	09-55215	35-524
09-779-01					
09-779-02					
09-779-04					
Rotax 550 F/C alla modeller					
<b>09-761</b>	69,50	<b>436 2-cyl</b>	710-025 1971-76	09-55128	35-505
09-761-01		<b>467 2-cyl</b>	710-165C 1990-91	09-55105	35-505
09-761-02		<b>467 2-cyl</b>	710-165E 1992-93	09-55105	35-505
09-761-04		<b>467 2-cyl</b>	710-203 1994-95	09-55105	35-505
MM.Rotax 444, 467; Elite 450 LC 1978-79; Everest 444 LC 1978-79; Everest 464 LC 1980-83; SS-25 1984					
<b>09-740</b>	69,00	<b>247 F/C 1-cyl</b>		09-118	35-505
09-740-02		<b>250 F/C 1-cyl</b>			35-505
Spirit 250 1979-83; Elan 250 1979-96; Spirit 250 1976-78; Elan 250 E 1971-78					

<b>Skidoo, Lynx</b>	<b>Borrning</b>	<b>Motortyp</b>	<b>Packningsatts</b>	<b>Packbox</b>	<b>Nållager</b>
<b>09-741</b>	72,00	<b>503 F/C</b>	710-162 1979-90	09-55103	35-505
09-741-01			710-162 1991-94	09-55104	
09-741-02			710-196 1995-03	09-55104	
09-741-04		<b>532 L/C</b>	710-169	09-55103	
09-741-06		<b>537 L/C</b>	710-177 1989-91	09-55105	
Rotax 503,521,536 Lynx, Nordik, Ockelbo, Skidoo, Trapper, Winha,					
<b>09-741</b>	72,00	<b>253 F/C</b>	710-164 1985-	09-55102	35-505
		<b>277 F/C</b>	710-195 1993-2009	09-55154	35-505
Lynx 250, Citation, Tundra, Tundra II, Freestyle, Scandik Tundra, GL 2300,					
<b>09-752</b>	67,50	<b>447 F/C</b>	710-162C 1984-90	09-55103	35-505
09-752-01			710-162C 1990-91	09-55104	35-505
09-752-02			710-210 1996-07	09-55104	35-505
09-752-04					
Forest Fox; Ockelbo, Skidoo, Trapper, Scandic 440 LT 2001-07, MXZ 440 1999-01, TOUR. E 1999-					
<b>09-751</b>	62,00	<b>377 F/C</b>	710-023A 1980-89	09-55103	35-505
09-751-01			710-023C 1990-94	09-55104	
09-751-02			710-210 1995-2006	09-55104	
09-751-04					
09-751-06					
Rotax 377 ; Lynx, Nordik, Ockelbo, Skidoo, Trapper, Winha					
<b>09-760</b>	67,50	<b>436,6 F/C</b>	710-163C	09-55101	35-505
09-760-01					
09-760-02					
09-760-04					
Blizzard 9500 1979-82; Ultra Sonic 1980-82					
<b>09-759 right</b>	67,50	<b>436,6 F/C</b>	710-025	09-55128	
09-759-02					
<b>09-758 left</b>	67,50				
09-758-02		<b>436,6 F/C</b>			
Everest 440 FC 1974-79; TNT 440 FC 1975-78; Olympic 1977; Futura 440 1975-79; Nuvik 440 1977					
<b>09-750</b>	59,50	<b>339 F/C</b>	N/A	09-165, 09-167	35-505
Blizzard 6500 Plus, 7500 Plus, Cross Country 1978-81; Super Sonic 1979-81					
<b>09-748</b>	59,50	<b>339 F/C 2-cyl</b>	N/A	09-167	35-505
09-748-02					
09-748-04					
<b>09-747</b>	59,59	<b>339 F/C 2-cyl</b>	N/A	09-167	35-505
09-747-02					
09-747-04					
TNT 340, 1972-76; Olympic 340, E 1975-79; Everest 340, E 1977-79; Futura 340 1975; Nuvik 340, E 76-79					
<b>09-746</b>	78,00	<b>335 F/C 1-cyl</b>	N/A	09-118	35-505
09-746-02					
Olympic 335 1969-72; Skandic 1970-73					
<b>09-745</b>	54,00	<b>247 F/C 2-cyl</b>	710-119	09-118	35-514
09-745-02					
Elan 250 1973-79					
<b>09-742</b>	76,00	<b>319 F/C 1-cyl</b>	N/A	09-118	35-505
09-742-02					
Olympic 320, 320E 1969; Olympic 300, S, M, 1971-77					

<b>Polaris</b>	<b>Borrning</b>	<b>Motortyp</b>	<b>Packningsatts</b>	<b>Packbox</b>	<b>Nållager</b>
<b>09-730</b>	85,00	<b>800 2-cyl</b>	710-252	09-55193	35-526
Indy 800 XC SP 2001-05, 800 SKS 2003, 800 Classic 2004, 800 LE 2001, 800 Pro X 2003-04, 800 Edge 04					
<b>09-718</b>	66,50	<b>679 3-cyl</b>	710-206	09-55186	35-503
Indy Ultra SP, Ultra SPX, SE, Ultra Touring 1996-97					
<b>09-719</b>	72,00	<b>794 3-cyl</b>	Kolla hemsida	09-55177	35-503
Indy Storm 800 1994-98					
<b>09-728</b>	77,25	<b>600 2-cyl</b>	710-251	09-55194	
Indy 600 Classic, Touring 2001, Indy 600 Touring 2000, 600 XC SP, Edge 2000, 600 XC SP 2001					
<b>09-716</b>	65,00	<b>567 3-cyl</b>	710-204 1994-96	09-55107	
09-716-01			710-205 1997-		
09-716-02					
Indy XLT 600 1995-98; XLT SP 1997-98; Indy XCR 600 1995-97; XC 600 1997					
<b>09-713</b>	67,75	<b>648 3-cyl</b>	710-181A		
09-713-01			Indy, Indy SKS	09-55107 88-92	
09-713-02			Indy RXL, SKS, EFI	09-55108 90-97	
09-713-04					
Indy 650, SKS 1988-93; Indy 650, RXL, SKS, 1990-97					
<b>09-714</b>	64,00	<b>580 3-cyl</b>	710-191 1992-94	09-55107	35-525
09-714-01			710-204 1994		
09-714-02					
09-714-04					
Indy 580 XLT, SKS, XLT SP 1993-94					
<b>09-707</b>	65,00	<b>398 2-cyl</b>	710-109C	09-55107	
09-707-02		<b>597 3-cyl</b>	710-175		
09-707-04					
Indy 400 1984-1991; Indy 600 1984-87					
<b>09-720</b>	70,50	<b>500 2-cyl</b>	710-237 1999-01	09-55194	35-507
09-720-02			710-250 2002-		
RMK 500, SKS 2000-02, 500 XC1999-02, Indy500 99, Indy 500 XC SP 1999-07, Indy 500 2001					
<b>09-727</b>	73,00	<b>550 F/C</b>	710-238 1998-2003	09-55196	35-503
09-727-01			710-286 1994-	09-55218	
09-727-02					
09-727-04					
Indy 550 Classic, Sport Touring, Supersport 1999-2006, Pro X Fan					
<b>09-711</b>	72,00	<b>488 L/C</b>	710-185A 1989-95	09-55107	35-503
09-711-01			710-208 1996-99	09-55107	
09-711-02		<b>( 500 ) L/C</b>	710-253 2000-2012	09-55187	
09-711-04					
Indy 500 LC, Classic 1989-00; Indy 500, SKS, SP, 1990-98; Indy 500 EFI 1992-98; Widetrack 1997-2012					
<b>09-712 (=711 )</b>	72,00	<b>488 F/C</b>	710-109C	09-55107	35-503
Indy Trail FC 1986; Super Sport 1997-98; Supertrac 1991-93; Indy Trail, Touring 1994-99					
<b>09-710</b>	67,75	<b>440 2-cyl</b>	710-186	09-55107	35-503
09-710-02					
09-710-04					
Indy Sport 1991-98; Sport GT 1991-93; Sport Touring 1995-98; Super Sport 1995-96; Transport 1996-98					
<b>09-715</b>	67,72	<b>440 2-cyl</b>	Kolla hemsida	Tarkista	35-505
09-715-01					
09-715-02					
Indy Lite, DeLuxe; Indy Lite Gt 1994-98; Indy Lite Touring 1998					

<b>Polaris</b>	<b>Borring</b>	<b>Motortyp</b>	<b>Packningsatts</b>	<b>Packbox</b>	<b>Nållager</b>
<b>09-717</b>	62,30	<b>340 2-cyl</b>	710-173	09-55107	35-525
09-717-01					
09-717-02					
09-717-04					
Indy Lite, DeLuxe; Indy Lite Gt 1994-98; Indy Lite Touring 1998					
<b>09-709</b>	62,25	<b>339 2-cyl</b>	710-173	09-55107	35-525
09-709-01					
09-709-02					
09-709-04					
Sprint ES 1986-90; Indy Sport, GT 1987-90; Indy Lite, GT, Starlite 1991-93					
<b>09-708</b>	61,78	<b>333 2-cyl</b>	710-073	09-55107	35-513
09-708-02					
Colt SS 340 1977; Cobra 340 1978-79; SS 340 1979; Apollo, Galaxy, Cutlass 340 1979-1981					
<b>09-706-02</b>	62,50	<b>336 2-cyl</b>	710-075A	09-55130	35-513
Starfire 340. 1976, TX 340 F/A 1973-82					
<b>09-705</b>	67,75	<b>440 2-cyl</b>	710-079	09-140 x 2	35-520
TX 440 1976-80					
<b>09-704</b>	67,72	<b>432 2-cyl</b>	710-078	09-55107	35-520
09-704-02					
TX-C 440C 1981; Long Track 1983-86; Sport, Super Sport SS 1983; TX 440 1973; Cobra 440 1978-79;					
<b>09-703</b>	53,40	<b>250 1-cyl</b>	710-069	09-55130	35-520
Starfire 250 1976; TX 250 1976-79					
<b>09-702</b>	53,50	<b>250 1-cyl</b>	710-069	09-55130	35-520
Colt 250 1976-78					
<b>09-700</b>	72,00	<b>244 1-cyl</b>	710-069	09-55130	35-520
09-700-02		<b>488 2-cyl</b>		09-55107	35-520
Electra 250 1975-77; Gemini 244 1979-83; Star 1983-90; Startrak 1987-90; Starlite Gt 1991-95					
<b>Kohler</b>					
09-670-02	62,50	<b>340 2-cyl</b>		09-104, 09-113	35-513
09-670-04					
Lynx, Winha mm					
<b>Sachs</b>					
<b>09-SM127</b>	67,40	<b>440 2-cyl</b>		09-116, 09-127	
Lynx , Winha mm					
<b>09-801</b>	72,96	<b>290 1-cyl</b>			
09-801-01		Notera: Kolven är 1 mm lägre, kolvskörten är 2 mm kortare			
09-801-02		men är ok att använda			
09-801-04					
Lynx, Ockelbo, Winha					
<b>Kawasaki</b>					
<b>09-689</b>	68,00	<b>440 2-cyl</b>		09-14603 x 2	35-522
Kawasaki 440 Kawasaki Intriguer, Intruder, Invader; Drifter 440 1978-81					
<b>09-685</b>	60,00	<b>339 2-cyl</b>		09-14603 x 2	35-525
Invader 340 F/C 1978-80, Inviter 340 F/C 1978, Drifter F/C 1979-81					

### Rotax 503-253

10-741-00  
10-741-01  
10-741-02  
10-741-04

### Kolvringar

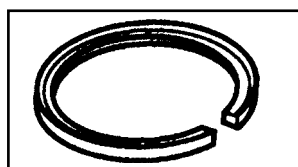

59

### Rotax 377

10-751-00  
10-751-01  
10-751-02  
10-751-04

### Kolvbult

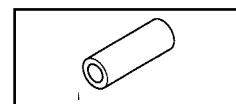













11-741  
11-751

<b>Yamaha</b>	<b>Borrning</b>	<b>Motortyp</b>	<b>Packningsatts</b>	<b>Packbox</b>	<b>Nållager</b>
<b>09-826</b>	74,80	<b>598 2-cyl</b>	710-201	09-55188	35-521
09-826-02					
V-Max 600, LE, DX, ST, 1994-96					
<b>09-817</b>	73,00	<b>569 2-cyl</b>	710-171	09-55170	35-521
09-817-02					
09-817-04					
Exciter 570, 1987-90 Exciter 2, 1991-92					
<b>09-816</b>	73,00	<b>535 2-cyl</b>	710-140A	09-55169	35-521
VMX 540 1983-91					
<b>09-808</b>	73,00	<b>535 2-cyl</b>	710-167 1979-90	09-55133	35-521
09-808-01			710-182 VK540 1988-2005; 09-55133		35-521
09-808-02					
09-808-04					
EC 540 1979-84 SR 540 1980-91 XL 540 1985-90 VK 540 1988-00					
<b>09-825</b>	68,00	<b>493 2-cyl</b>	710-200	09-55188	35-521
V-Max 500 LE, DX, ST, 1994-96					
<b>09-813</b>	72,00	<b>485 2-cyl</b>	Kolla vår hemsida	Kolla	35-505
09-813-01					
09-813-02					
09-813-04					
PZ 480 84-98 480 ST 91-98 VT 480 91-97 VT 480 GT 93-99 VT 480 TF/X 93-00; Venture 500 1999-06					
<b>09-806</b>	68,00	<b>433 2-cyl</b>	710-146	09-55131	35-505
09-806-01					
09-806-02					
09-806-04					
GP; TL, 433 1975 EX 440 1976-81 GP 440 1976-78 PR 440 1976-77 STX 1976-77					
<b>09-807</b>	66,00	<b>440 2-cyl</b>	710-147C	09-55133	35-505
09-807-02					
SS 440 1980-83					
<b>09-814</b>	68,00	<b>433 2-cyl</b>		09-137, 09-143	35-505
09-814-02					
09-814-04					
SR 433, GPX 433 1971-75					
<b>09-815</b>	60,00	<b>338 2-cyl</b>		09-137, 09-143	35-505
09-815-01					
09-815-02					
GPX 338 F/A 1974-75					
<b>09-804</b>	60,00	<b>338 2-cyl</b>	710-141	09-137, 09-143	35-505
09-804-02					
EX 340 1976-78 STX 340 1976-1977					
<b>09-803</b>	60,00	<b>338 2-cyl</b>	710-100	09-55133	35-505
09-803-04					
GP 338 1973 SL 338 1974 GS 338, 340 1976-1979					
<b>09-802</b>	60,00	<b>337 2-cyl</b>	710-142	09-131, 09-132	35-522
09-802-01					
09-802-02					
09-802-04					
EC 340 1982-88 ET 340 1978-88 CS 340 1989-00					

Yamaha	Borrning	Motortyp	Packningsatts	Packbox	Nållager
<b>09-800</b>	70,00	<b>246 1-cyl</b>	710-027	09-131, 09-132	35-505
09-800-01					
09-800-02					
Br 250 1982-94 Br 250T, TS 1985-00; BR 250 TS 1984-97					
<b>09-801</b>	72,96	<b>246 1-cyl</b>	710-138	09-131, 09-132	35-505
09-801-01					
09-801-02					
09-801-04					
ET 250 1977-81					
<b>09-812</b>	73,00	<b>292 1-cyl</b>			35-505
09-812-01					
GP 292 1972-73 SM 292 1973-74					
<b>09-811</b>	56,00	<b>292 2-cyl</b>	710-138B	09-135, 09-143	35-505
09-811-02					
ET 300 1980-84					
<b>09-810-02</b>	73,50	<b>292 1-cyl</b>			35-505
SL 292 1971-72					

## Packningar, avgasgrenrör

<b>718-057 Arctic Cat</b>	<b>718-059 Arctic Cat</b>	<b>718-024 Rotax</b>	<b>718-163 Rotax</b>
			
<b>340 F/C</b>	<b>370,440,500,600</b>	<b>377, 447 F/C</b>	<b>503, 550 F/C</b>
<b>718-177 Rotax</b>	<b>718-178 Rotax</b>	<b>718-185 Rotax</b>	<b>718-192 Rotax</b>
			
<b>582, 58 L/C</b>	<b>700,800,440,583</b>	<b>600 L/C</b>	<b>500 L/C</b>
<b>718-164 Polaris</b>	<b>718-071 Polaris</b>	<b>718-109 Polaris</b>	<b>718-184 Polaris</b>
			
<b>600, 700 U.S.</b>	<b>340,440,448</b>	<b>LC Fuji, 340 F/C</b>	<b>440 L/C</b>
<b>718-186 Polaris</b>	<b>718-187 Polaris</b>	<b>718-190 Polaris</b>	<b>718-028 Yamaha</b>
			
<b>440,544 F/C</b>	<b>500,660 U.S</b>	<b>440,700,800 U.S</b>	<b>Nästan alla</b>

# Startmotorer

passar på; OEM p:no

01-0192



DG-0058-1

9-kuggar  
Drive gear



CB-0092-10

Kolbrygga  
Komplett



**Polaris:**

417 0006, 241 0748

01-0201



DG-0058-1

9-kuggar  
Drive gear



CB-0092

Kolbrygga  
Komplett



**Arctic Cat:**

0745-018, 0745-030,  
0745-052, 0745-257  
0745-357

1991-2007

01-0202



CB-0092-1

Kolbrygga  
Komplett



**Arctic Cat:** 0645-183

0654-312, 0645-578

1995-2002

01-0203



CB-0092-10

Kolbrygga  
Komplett



**Arctic Cat:** 0745-143

0745-126, 0745-356

2001-2007

01-0204



DG-0091-1

8-kuggar  
Drive gear



CB-0210

Kolbrygga  
Komplett



**BRP:** 515-176-003

515-176-113, 515-175-562

515-175-843

2000-2007

01-0205



**nyhet!!!**

**BRP: 410-212-400**

01-0206



DG-0092-1

9-kuggar  
Drive gear



CB-0063

Kolbrygga  
Komplett



**Yamaha:**

8BB- 81800-01-00

8BB- 81800-00-00

8Y3- 81800-51-00

1988-2005

01-0207



DG-0093-1

9-kuggar  
Drive gear



CB-0140-1

Kolbrygga  
Komplett



**Yamaha:**

8CW-81800-00-00

8CW-81800-01-00

1997-2003

01-0228



DG-0095-1

9-kuggar  
Drive gear



CB-0140-1

Kolbrygga  
Komplett



**Kubota:**

Kubota: 70000-65440

Denso: 228000-6910

Denso: 228000-6911

01-0229



DG-0095-1

9-kuggar  
Drive gear



CB-0140-1

Kolbrygga  
Komplett



**BRP:**









410-207-500

Lynx, Skandic Rotax 494

1997-2000

Arctic Cat	Arctic Cat	Arctic Cat	Arctic Cat
05-15225 par	05-15232 par	05-15240 par	05-15241 st
0109-932	0115-603	0702-264	0702-229
			
Arctic Cat	Polaris	Polaris	Polaris
05-15244 par	05-15214 st	05-15231 st	05-15237 st
0702-563 v. 2006-	1930 723	1930 588	1930 586
			
Polaris	Polaris	Polaris, 2201430,	Polaris
05-15243 par	05-15255 par	05-15251 par	05-15254 par
1930 723	220 1567, 2001-		2003-2011 IQ, Indyt
			
Polaris	Polaris, 220 1429	Skidoo, Lynx	Skidoo
05-15203 par	05-15252 par	05-15235 par	05-15247 par
193034 7/5		Nordik	860.701.700
			
Skidoo, Lynx	Skidoo, Lynx	Skidoo, Lynx	Skidoo, Lynx
05-15212 par	05-15242 par	05-15246 par	05-252FM, par
860.701.400	860.700.700	414.990.900	507-032-473
			
Lynx		Lynx	
85-184 st		85-183 Lynx 5900	Lynx 85-162
1986-1993		Lynx 535, 3900, 650	Lynx 535, 3900, 650
			

## Bromsbelägg

Yamaha 05-15224 par	Yamaha 05-15249, 05-15250	Yamaha 05-15226 st	Yamaha 05-15228 st
			
Yamaha	05-15245 st	Yamaha 05-451FM	Yamaha 05-450FM
			Ej bild  Vector, Phazer 2006-
Ockelbo 85-179	15-00 Velsa variatorfjäder	37-08 Ockelbo fjädringsgummi	
			

## Huvstroppar

Aktiv	12-131	Lynx, Yamaha	12-13402	Polaris	12-135
					
Polaris	12-13501	Arctic Cat	12-130	Skidoo	12-132
					

Skidoo 12-261

Skidoo 12-260

12-165 Backspegel

## Dekaler

00-600



00-601



# CDI-Boxar



**01-14342**  
Rotax 410.918.900



**01-14343**  
Rotax 420.965.591



**01-401**  
Arctic Cat 3004-099



**01-14340**  
Rotax 420.866.595



**01-415**  
Yamaha 8V0.85540.21



**01-407**  
Polaris 3083725



**01-14345**  
Rotax 420.965.757



**01-40701**  
Polaris 3083989



**01-40801**  
Polaris 3084007



**01-14329**  
Arctic Cat 3003-777



**01-14372**  
Skidoo 512.058.927 Form.

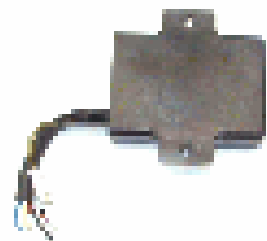

**01-406**  
Pol. 3083721 600-650



**01-404**  
Polaris 308 3723



**01-14327**  
Arctic Cat



**01-14341**

# Tändspolar



**01-14310**  
Rotax 410.916.000



**01-14311**  
Rotax 410.913.500 Arctic



**01-14319**



**01-14312**  
Arctic Cat 3003-221



**01-14313**  
Polaris 3082974



**01-143120**  
Arctic Cat 3003-977



**01-14314**  
Yamaha 8W3.82310.10



**01-14315**  
Yamaha 8E7.82310.10



**01-14317**  
Yamaha 5.82310.40



**01-14351**  
Yamaha 8AB.82310.10



**01-14353**  
Arctic Cat 3003-575



**01-14355**  
Rotax 10.920.500



**01-14350**  
Yamaha Bravo 250 -88



**01-14363**  
AC 3005-381 ZL-ZR 5-700



**01-14371**  
Rotax 420.996.705  
Form. III, Mach1, Z, ZR

## Tändspolar



**01-14360**  
Arctic Cat 3004-126



**01-14361**  
Arctic Cat 3004-483



**01-14362**  
Polaris 3084469



**01-1430**  
Rotax, Bosch, Arctic Cat



**01-14367**  
Polaris 3085293



**01-14370**  
Formula 415.085.400

## Nödstop



**01-113** Arctic Cat



**01-11121**  
Skidoo 515.1515.00



**01-11120**  
Skidoo



**01-11113**  
Yamaha, Arctic Cat, Polaris



**01-112**

## Ljusspole



**01-14332**  
Bosch, Skidoo,  
Motoski



**01-120**  
Universal, gamla  
Tryck-stop-mod

## Tändstift



**05-B8** BR8ES resistor  
**05-B9** BR9ES resistor

# Voltregulator

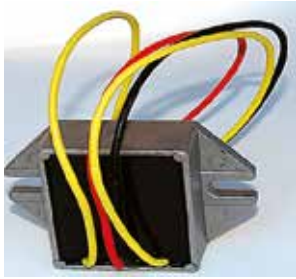

**01-15416** 3 tråd  
**01-15416B** 4 tråd



**01-15402**  
Rotax 410.908.900



**01-15406**  
Rotax, Arctic Cat



**01-15421**  
Polaris 4060122



**01-15417** 250 W  
Tasasuuntaaja Rotax



**01-15415**  
Rotax 410.908.900



**01-15436**  
Yamaha 98A.81910.00



**01-15418**  
Tasasuuntaaja Arctic Cat



**01-15426**  
Arctic Cat 0232-014



**01-15432**  
Yamaha 82F.81910.

# Tändhatt



**01-15435**  
Yamaha 82M.81910.AO



**01-110**



**01-1101**

# Laddare 12V



**01-100**

# RIPSAW FULL

Model 9002U

- "Full block" lugs provides traction for soft, loose snow
- Aggressive angled lugs for outstanding forward and lateral bite on hard-packed snow
- "Chopped" lug design increases traction and braking on hard-packed snow
- Rigid lugs deliver excellent durability and longevity for miles and miles of use



MODEL	DIMENSIONS	LUG HEIGHT	WEIGHT	DRIVE PITCH	CLIP CONFIG.
9002U	20" x 156" (50 cm x 396 cm)	1.25" (32 mm)	68 lbs (31 kg)	2.52" (64 mm)	Full
9089U	20" x 154" (50 cm x 391 cm)	1.375" (35 mm)	66 lbs (30 kg)	2.86" (73 mm)	Full
9151U	20" x 156" (50 cm x 396 cm)	1.25" (32 mm)	68 lbs (31 kg)	2.52" (64 mm)	Full

# ICE WIDE TRACK

Model 9008U

- Factory pre-studded for improved traction and confidence
- Finger designed lugs deliver superior traction on hard-packed snow

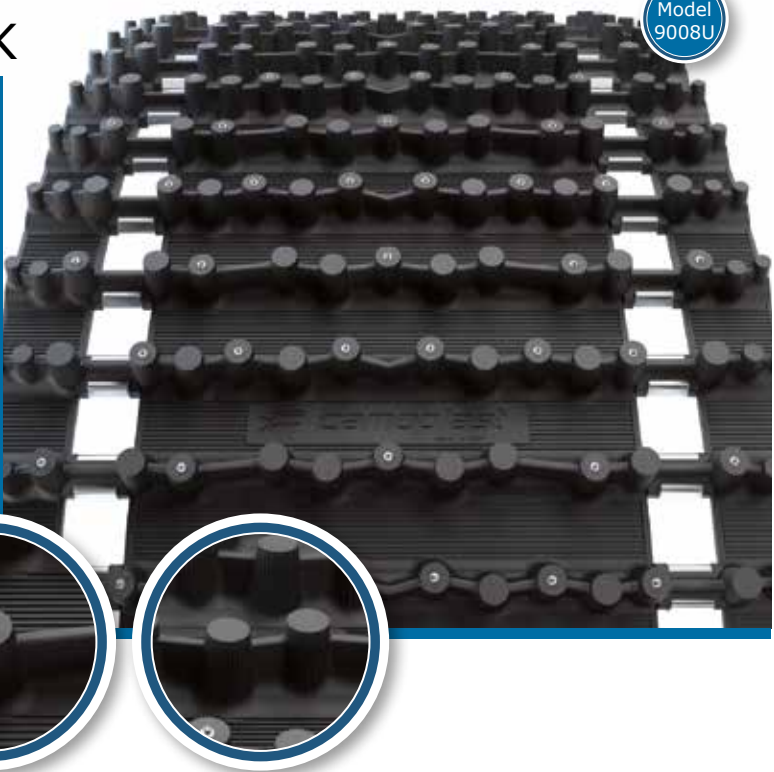

MODEL	DIMENSIONS	LUG HEIGHT	WEIGHT	DRIVE PITCH	CLIP CONFIG.
9008U	20" x 156" (50 cm x 396 cm)	1.25" (32 mm)	72 lbs (33 kg)	2.52" (64 mm)	Full

# NEW COBRA WT

# New COBRA WT600

UTILITY

The Camoplast Cobra WT is a no-compromises solution for off-trail work and play.

- Extra tall 1.5" and 1.8" lugs provide optimal traction on and off-trail applications
  - Cupped lugs deliver excellent traction in soft, loose snow and off-trail
  - back country explorations
  - Lightweight for improved efficiency and fuel economy
- High-performance belting pulls heavier loads without track stretching



MODEL	DIMENSIONS	LUG HEIGHT	WEIGHT	DRIVE PITCH	CLIP CONFIG.
9195U20"	154" (50 cm x 392 cm)	1.8" (46 mm)	65 lbs (29 kg)	2.86" (73 mm)	Full
9196U20"	154" (50 cm x 392 cm)	1.5" (38 mm)	62 lbs (28 kg)	2.86" (73 mm)	Full
<b>Nyhet</b> 9260U24"	154" (60 cm x 392 cm)	1.8" (46 mm)	xx lbs (xx kg)	2.86" (73 mm)	Full
9261U24"	154" (60 cm x 392 cm)	1.5" (38 mm)	xx lbs (xx kg)	2.86" (73 mm)	Full

04-7000 60 x 396 cm look at the page 80



Model 9195U

# ENERGY

Model  
9793H144

Economical general replacement track

Lightweight design provides good fuel economy and low rolling resistance

Narrow lug base means less rolling resistance for maximum top speed

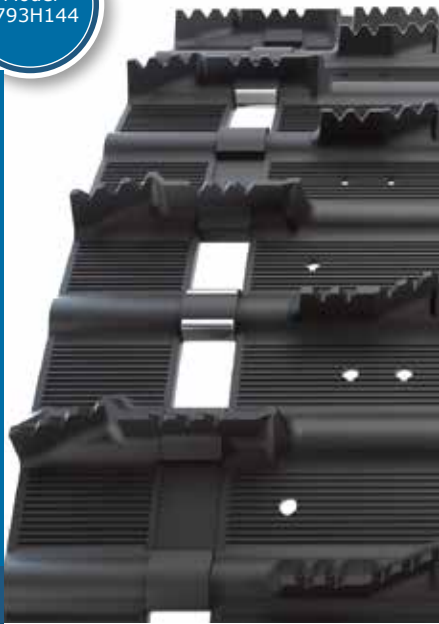

# HACKSAW

Model  
9043H144  
TRACKtion Control™



TRAILS

MODEL	DIMENSIONS	LUG HEIGHT	WEIGHT	DRIVE PITCH	CLIP CONFIG..
9793T	15" x 121" (38 cm x 307 cm)	1" (25 mm)	32 lbs (15 kg)	2.52" (64 mm)	Every 3 <sup>rd</sup> / closed windows Energy
9794T	15" x 136" (38 cm x 345 cm)	1" (25 mm)	36 lbs (16 kg)	2.52" (64 mm)	Every 3 <sup>rd</sup> / closed windows Energy
9147H	15" x 121" (38 cm x 307 cm)	1" (25 mm)	32 lbs (15 kg)	2.52" (64 mm)	Every 3 <sup>rd</sup> / open windows Hacksaw
9960H	13.5" x 128" (34 cm x 325 cm)	1" (25 mm)	32 lbs (15 kg)	2.52" (64 mm)	Every 3 <sup>rd</sup> / closed windows Hacksaw

# RIPSAW

Mallit  
9968H144 &  
9969H162  
TRACKtion Control™

Aggressive angled profiles for outstanding forward and lateral bite on groomed trails

"Chopped" lug design means superior handling, acceleration and braking on hard-packed groomed trails

Narrow lug base means less rolling resistance for maximum top speed

Rigid lugs provide excellent durability and longevity for miles and miles of use



MODEL	DIMENSIONS	LUG HEIGHT	WEIGHT	DRIVE PITCH	CLIP CONFIG..
9001H	13.5" x 128" (34 cm x 325 cm)	1.25" (32 mm)	34 lbs (15 kg)	2.52" (64 mm)	Every 3 <sup>rd</sup> / closed windows
9040H	15" x 128" (38 cm x 325 cm)	1.25" (32 mm)	41 lbs (19 kg)	2.52" (64 mm)	Full
9146H	15" x 121" (38 cm x 307 cm)	1.25" (32 mm)	35 lbs (16 kg)	2.52" (64 mm)	Every 3 <sup>rd</sup> / open windows
9148H	15" x 120" (38 cm x 305 cm)	1" (25 mm)	32 lbs (15 kg)	2.86" (73 mm)	Full
9149H	15" x 120" (38 cm x 305 cm)	1.25" (32 mm)	34 lbs (15 kg)	2.86" (73 mm)	Full
9968H	15" x 121" (38 cm x 307 cm)	1.25" (32 mm)	38 lbs (17 kg)	2.52" (64 mm)	Full
9969H	15" x 136" (38 cm x 345 cm)	1.25" (32 mm)	43 lbs (20 kg)	2.52" (64 mm)	Full

# COBRA

Cupped lugs for superior handling, acceleration and braking in soft loose snow trails

Flexible lug design means excellent off-trail performance without sacrificing top speed

Reduced track noise

Unique traction teeth for extra grip on hard-packed snow surfaces



TRAILS

MODEL	DIMENSIONS	LUG HEIGHT	WEIGHT	DRIVE PITCH	CLIP CONFIG.
9052H	15" x 121" (38 cm x 307 cm)	1.352" (34 mm)	37 lbs (17 kg)	2.52" (64 mm)	Full
9061H	15" x 136" (38 cm x 345 cm)	1.352" (34 mm)	42 lbs (19 kg)	2.52" (64 mm)	Full
9081H	15" x 128" (38 cm x 325 cm)	1.352" (34 mm)	40 lbs (18 kg)	2.52" (64 mm)	Full
9092H	15" x 120" (38 cm x 305 cm)	1.352" (34 mm)	33 lbs (15 kg)	2.86" (73 mm)	Full
9093H	15" x 137" (38 cm x 348 cm)	1.352" (34 mm)	xx lbs (xx kg)	2.86" (73 mm)	Full
9094H	15" x 146" (38 cm x 371 cm)	1.352" (34 mm)	40 lbs (18 kg)	2.86" (73 mm)	Full
9107H	15" x 144" (38 cm x 366 cm)	1.352" (34 mm)	44 lbs (20 kg)	2.52" (64 mm)	Full
9114H	16" x 137" (41 cm x 348 cm)	1.352" (34 mm)	40 lbs (18 kg)	2.86" (73 mm)	Full
9235H	15" x 129" (38 cm x 326 cm)	1.352" (34 mm)	36 lbs (16 kg)	2.86" (73 mm)	Full

## COBRA 1,6 & ICE COBRA 1,6



MODEL	DIMENSIONS	LUG HEIGHT	WEIGHT	DRIVE PITCH	CLIP CONFIG.
9244C	15" x 120" (38 cm x 305 cm)	1.352" (41 mm)	xx lbs (xx kg)	2.86" (73 mm)	Full
9245C	15" x 129" (38 cm x 327 cm)	1.352" (41 mm)	xx lbs (xx kg)	2.86" (73 mm)	Full
9246C	15" x 137" (38 cm x 348 cm)	1.352" (41 mm)	xx lbs (xx kg)	2.86" (73 mm)	Full
9249C	16" x 137" (38 cm x 348 cm)	1.352" (41 mm)	xx lbs (xx kg)	2.86" (73 mm)	Full
9262C	15" x 120" (38 cm x 305 cm)	1.352" (41 mm)	xx lbs (xx kg)	2.86" (73 mm)	Full
9263C	15" x 129" (38 cm x 327 cm)	1.352" (41 mm)	xx lbs (xx kg)	2.86" (73 mm)	Full
9264C	15" x 137" (41 cm x 348 cm)	1.352" (41 mm)	xx lbs (xx kg)	2.86" (73 mm)	Full
9265C	16" x 137" (38 cm x 348 cm)	1.352" (41 mm)	xx lbs (xx kg)	2.86" (73 mm)	Full

**New, studs**

**New, no studs**

# NEW RIPSAW II

New lug design combines the best features of RipSaw, Cobra and Predator for excellent performance on a wide variety of trail conditions

Less side bite through the corners than the original RipSaw  
Less track noise for quieter operation on hard-packed groomed trails

1" lug height for good top speed

1.25" lug height for better traction, handling and stability



MODEL	DIMENSIONS	LUG HEIGHT	WEIGHT	DRIVE PITCH	CLIP CONFIG.
9156H	15" x 120" (38 cm x 305 cm)	1.25" (32 mm)	36 lbs (16 kg)	2.86" (73 mm)	Full
9158H	15" x 120" (38 cm x 305 cm)	1" (25 mm)	32 lbs (15 kg)	2.86" (73 mm)	Full
9214H	15" x 121" (38 cm x 307 cm)	1.25" (32 mm)	41 lbs (19 kg)	2.52" (64 mm)	Full
9215H	15" x 128" (38 cm x 325 cm)	1.25" (32 mm)	43 lbs (20 kg)	2.52" (64 mm)	Full
9216H	15" x 136" (38 cm x 345 cm)	1.25" (32 mm)	45 lbs (20 kg)	2.52" (64 mm)	Full
9223H	15" x 137" (38 cm x 348 cm)	1.25" (32 mm)	42 lbs (19 kg)	2.86" (73 mm)	Full
9224H	15" x 137" (38 cm x 348 cm)	1" (25 mm)	38 lbs (17 kg)	2.86" (73 mm)	Full
9237H	15" x 129" (38 cm x 326 cm)	1.25" (32 mm)	39 lbs (18 kg)	2.86" (73 mm)	Full
9209H	15" x 120" (38 cm x 305 cm)	1.25" (32 mm)	37 lbs (17 kg)	2.86" (73 mm)	Full
9210H	15" x 120" (38 cm x 305 cm)	1" (25 mm)	33 lbs (15 kg)	2.86" (73 mm)	Full

1.5" lugs provide aggressive traction for crossover riders who prefer on-trail riding

- Longer lengths – 144", 151" and 159" — allow conversion of mountain designed snowmobiles to crossover sleds for on and off-trail use
- Aggressive angled lugs offer outstanding forward and lateral bite on groomed trails "Stepped" lug design allows lugs to provide improved traction in soft, loose snow



Model 9003C

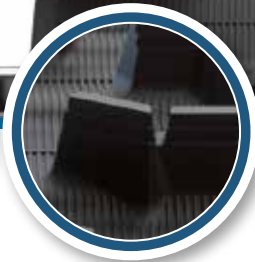

## SOKOSTI

MODEL	DIMENSIONS	LUG HEIGHT	WEIGHT	DRIVE PITCH	CLIP CONFIG.
9003C	15" x 144" (38 cm x 366 cm)	1.5" (38 mm)	50 lbs (23 kg)	2.52" (64 mm)	Full
9004C	15" x 151" (38 cm x 384 cm)	1.5" (38 mm)	52 lbs (24 kg)	2.52" (64 mm)	Full
9005C	15" x 159" (38 cm x 404 cm)	1.5" (38 mm)	51 lbs (23 kg)	2.52" (64 mm)	Every 3 <sup>rd</sup> / open windows

1.5" lugs provide aggressive traction for crossover riders who prefer on-trail riding

V-shaped and full lugs provide extra traction in soft, loose snow



Model 9108C



## INTENSE

MODEL	DIMENSIONS	LUG HEIGHT	WEIGHT	DRIVE PITCH	CLIP CONFIG.
9108C	15" x 136" (38 cm x 345 cm)	1.5" (38 mm)	41 lbs (19 kg)	2.52" (64 mm)	Full
9930C	15" x 121" (38 cm x 307 cm)	1.5" (38 mm)	39 lbs (18 kg)	2.52" (64 mm)	Full

1.5" lugs provide aggressive traction for crossover riders who prefer on-trail riding

- 14" width allows fitment for MY07-12 Yamaha Phazer FX,GT & RTX



Model 9033C



## FREERIDE

MODEL	DIMENSIONS	LUG HEIGHT	WEIGHT	DRIVE PITCH	CLIP CONFIG.
9033C	14" x 121" (36 cm x 307 cm)	1.5" (38 mm)	38 lbs (17 kg)	2.52" (64 mm)	Full
9034C	14" x 136" (36 cm x 345 cm)	1.5" (38 mm)	lbs (kg)	2.52" (64 mm)	Full
9044C	14" x 144" (36 cm x 365 cm)	1.5" (38 mm)	lbs (kg)	2.52" (64 mm)	Full
9047M	14" x 151" (36 cm x 384 cm)	2,25" (57 mm)	lbs (kg)	2.52" (64 mm)	Full

Huom

# CHALLENGER TRAIL

Model 9069C

CROSS-COUNTRY

- Provides superior off-trail capability without sacrificing trail performance
- Versatile performer inspired by Challenger mountain track design
- Saw-tooth 1.75-inch lugs provide excellent handling, acceleration, and braking on packed trails
- 16-inch width improves floatation in soft snow off trails

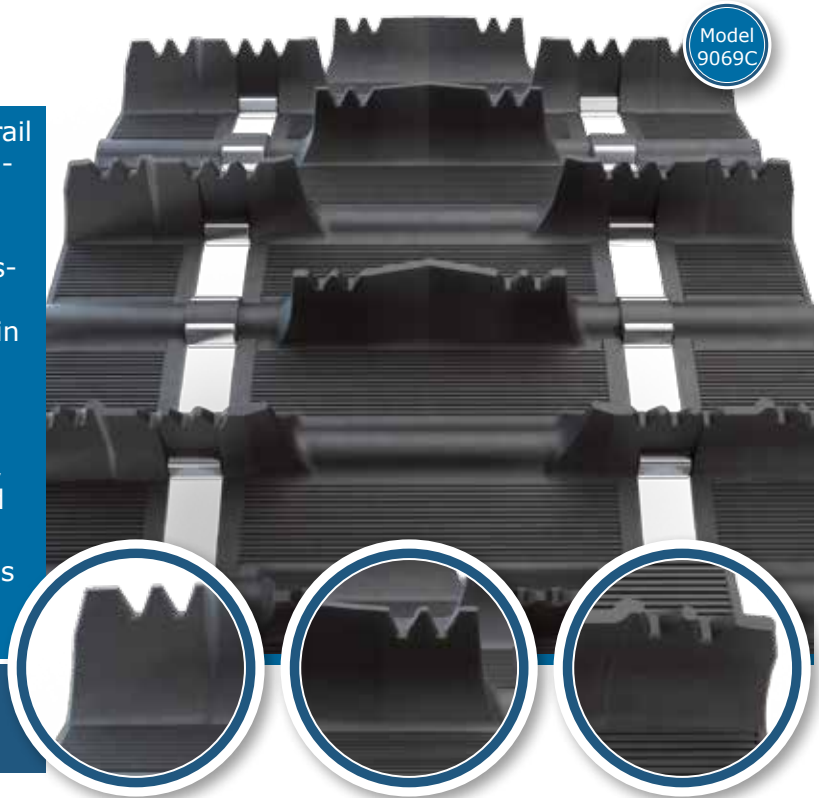

MODEL	DIMENSIONS	LUG HEIGHT	WEIGHT	DRIVE PITCH	CLIP CONFIG.
9069C	16" x 120" (41 cm x 305 cm)	1.75" (44 mm)	39 lbs (18 kg)	2.86" (73 mm)	Full
9070C	16" x 137" (41 cm x 348 cm)	1.75" (44 mm)	45 lbs (20 kg)	2.86" (73 mm)	Full
9167C	16" x 146" (41 cm x 371 cm)	1.75" (44 mm)	48 lbs (22 kg)	2.86" (73 mm)	Full
9933C	16" x 136" (41 cm x 345 cm)	1.75" (44 mm)	48 lbs (22 kg)	2.52" (64 mm)	Full

# RIPSAW 1.5

Model 9112C

- 1.5" lugs provide aggressive traction for crossover riders who prefer on-trail riding
- Aggressive angled lugs offer outstanding forward and lateral bite on groomed trails
- "Chopped" lug design for superior handling, acceleration and braking on groomed hard-packed trails
- Rigid lugs deliver excellent durability and longevity for miles and miles of riding



MODEL	DIMENSIONS	LUG HEIGHT	WEIGHT	DRIVE PITCH	CLIP CONFIG.
9045C	15" x 128" (38 cm x 325 cm)	1.5" (38 mm)	40 lbs (18 kg)	2.52" (64 mm)	Every 3 <sup>rd</sup> / open windows
9076C	15" x 137" (38 cm x 348 cm)	1.5" (38 mm)	42 lbs (19 kg)	2.86" (73 mm)	Full
9112C	15" x 121" (38 cm x 307 cm)	1.5" (38 mm)	41 lbs (19 kg)	2.52" (64 mm)	Full
9113C	15" x 136" (38 cm x 345 cm)	1.5" (38 mm)		2.52" (64 mm)	Full
9159C	15" x 120" (38 cm x 305 cm)	1.5" (38 mm)	37 lbs (17 kg)	2.86" (73 mm)	Full
9238C	15" x 129" (38 cm x 326 cm)	1.5" (38 mm)	40 lbs (18 kg)	2.86" (73 mm)	Full

# ENGINEERED FOR OUTSTANDING PERFORMANCE IN SOFT SNOW

- 1.75-inch lug bites deep for off-trail use
- Arched lug pattern for outstanding traction in soft snow
- 2.00-inch lugs are staggered for outstanding traction in soft snow
- Rigid lug support columns and optimized rubber compound for performance on and off trails

## BACKCOUNTRY X

- 2.86-inch drive pitch applications
- 3.00-inch drive pitch applications



### BACKCOUNTRY X

MODEL	DIMENSIONS	LUG HEIGHT	WEIGHT	DRIVE PITCH	CLIP CONFIG.
9125C	15" x 120" (38 cm x 305 cm)	1.75" (44 mm)	39 lbs (18 kg)	2.86" (73 mm)	Full
9126C	15" x 137" (38 cm x 348 cm)	1.75" (44 mm)	45 lbs (20 kg)	2.86" (73 mm)	Full
<b>9254C15"</b>	<b>x 141" (38 cm x 358 cm)</b>	<b>1.75" (44 mm)</b>	<b>xx lbs (xx kg)</b>	<b>3.00" (76 mm)</b>	<b>Full</b>

### BACKCOUNTRY X2

9256C	15" x 120" (38 cm x 305 cm)	2.00" (51 mm)	41 lbs (19,0 kg)	2.86" (73 mm)	Full
9257C	15" x 129" (38 cm x 327 cm)	2.00" (51 mm)	43 lbs (19,5 kg)	2.86" (73 mm)	Full
9258C	15" x 137" (38 cm x 348 cm)	2.00" (51 mm)	46 lbs (21,0 kg)	2.86" (73 mm)	Full

## BACKCOUNTRY

- 2.52-inch drive pitch applications



### BACKCOUNTRY

MODEL	DIMENSIONS	LUG HEIGHT	WEIGHT	DRIVE PITCH	CLIP CONFIG.
9140C	15" x 121" (38 cm x 307 cm)	1.75" (44 mm)	40 lbs (18 kg)	2.52" (64 mm)	Full
9141C	15" x 128" (38 cm x 325 cm)	1.75" (44 mm)	42 lbs (19 kg)	2.52" (64 mm)	Full
9142C	15" x 136" (38 cm x 345 cm)	1.75" (44 mm)	44 lbs (20 kg)	2.52" (64 mm)	Full
9143C	15" x 144" (38 cm x 366 cm)	1.75" (44 mm)	46 lbs (21 kg)	2.52" (64 mm)	Full

# SNO X

- 1.75" lugs are the choice of professional racers
- Extra hard outside rubber compound means good bite for the hole shot
- Track designs tested and proven by select OE factory race teams
- ISR approved for use in Mod class



RACING

MODEL	DIMENSIONS	LUG HEIGHT	WEIGHT	DRIVE PITCH	CLIP CONFIG.
9067R <sup>1</sup>	15" x 121" (38 cm x 307 cm)	1.75" (44 mm)	41 lbs (19 kg)	2.52" (64 mm)	Full
9068R <sup>1</sup>	15" x 128" (38 cm x 325 cm)	1.75" (44 mm)	43 lbs (20 kg)	2.52" (64 mm)	Full
9169R	15" x 120" (38 cm x 305 cm)	1.75" (44 mm)	40 lbs (18 kg)	2.86" (73 mm)	Full
9189R	15" x 129" (38 cm x 326 cm)	1.75" (44 mm)	43 lbs (20 kg)	2.86" (73 mm)	Full

# NEW ICE ATTAK XT



TRAILS

MODEL	DIMENSIONS	LUG HEIGHT	WEIGHT	DRIVE PITCH	CLIP CONFIG.
9190H	15" x 120" (38 cm x 305 cm)	1.22" (31 mm)	37 lbs (17 kg)	2.86" (73 mm)	Full
9191H	15" x 137" (38 cm x 348 cm)	1.22" (31 mm)	42 lbs (19 kg)	2.86" (73 mm)	Full
9200H	15" x 121" (38 cm x 307 cm)	1.22" (31 mm)	40 lbs (18 kg)	2.52" (64 mm)	Full
9201H	15" x 128" (38 cm x 325 cm)	1.22" (31 mm)	42 lbs (19 kg)	2.52" (64 mm)	Full
9202H	15" x 136" (38 cm x 345 cm)	1.22" (31 mm)	45 lbs (20 kg)	2.52" (64 mm)	Full
9203H	15" x 144" (38 cm x 365 cm)	1.22" (31 mm)	47 lbs (21 kg)	2.52" (64 mm)	Full
9236H	15" x 129" (38 cm x 326 cm)	1.22" (31 mm)	39 lbs (18 kg)	2.86" (73 mm)	Full

# ICE RIPPER XT



MODEL	DIMENSIONS	LUG HEIGHT	WEIGHT	DRIVE PITCH	CLIP CONFIG.
9077H	15" x 121" (38 cm x 307 cm)	1.25" (32 mm)	39 lbs (18 kg)	2.52" (64 mm)	Full
9078H	15" x 128" (38 cm x 325 cm)	1.25" (32 mm)	42 lbs (19 kg)	2.52" (64 mm)	Full
9079H	15" x 136" (38 cm x 345 cm)	1.25" (32 mm)	44 lbs (20 kg)	2.52" (64 mm)	Full
9164H	15" x 120" (38 cm x 305 cm)	1.25" (32 mm)	36 lbs (16 kg)	2.86" (73 mm)	Full
9173H	15" x 144" (38 cm x 366 cm)	1.25" (32 mm)	46 lbs (21 kg)	2.52" (64 mm)	Full

# CHALLENGER EXTREME

MOUNTAIN

- 2.5" and giant 3" lugs for boondocking the deepest, bottomless powder and climbing the steepest chutes
- Saw-tooth lug feature provides traction and grip on hard, wind-blown and springtime snow

Models  
9104M &  
9105M

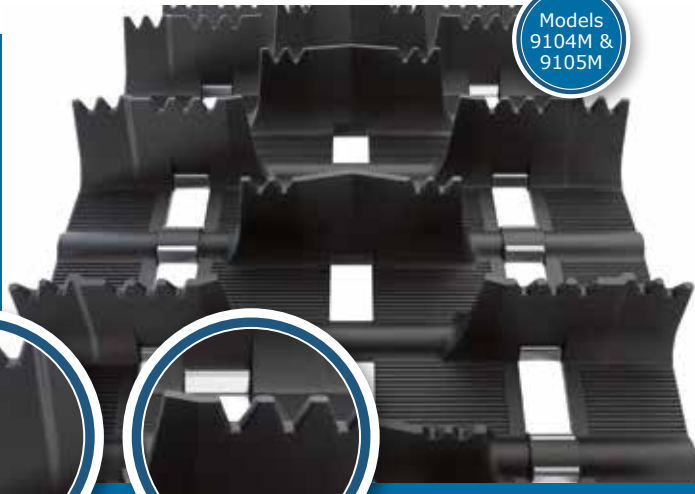

MODEL	DIMENSIONS	LUG HEIGHT	WEIGHT	DRIVE PITCH	CLIP CONFIG.
9035M	15" x 174" (38 cm x 442 cm)	2.5" (64 mm)	63 lbs (29 kg)	3" (76 mm)	Full
9036M	16" x 174" (41 cm x 442 cm)	2.5" (64 mm)	67 lbs (30 kg)	3" (76 mm)	Full
9102M	16" x 154" (41 cm x 391 cm)	2.5" (64 mm)	59 lbs (27 kg)	2.86" (73 mm)	Full
9103M	16" x 163" (41 cm x 414 cm)	2.5" (64 mm)	61 lbs (28 kg)	2.86" (73 mm)	Full
9104M <sup>1</sup>	15" x 154" (38 cm x 391 cm)	2.5" (64 mm)	55 lbs (25 kg)	2.86" (73 mm)	Full
9105M <sup>1</sup>	15" x 163" (38 cm x 414 cm)	2.5" (64 mm)	57 lbs (26 kg)	2.86" (73 mm)	Full
9115M	16" x 174" (41 cm x 442 cm)	3" (76 mm)	75 lbs (34 kg)	3" (76 mm)	Full
9144M	16" x 146" (41 cm x 371 cm)	2.5" (64 mm)	56 lbs (25 kg)	2.86" (73 mm)	Full
9145M <sup>1</sup>	15" x 146" (38 cm x 371 cm)	2.5" (64 mm)	52 lbs (24 kg)	2.86" (73 mm)	Full
9225M	16" x 156" (41 cm x 396 cm)	3" (76 mm)	68 lbs (31 kg)	3" (76 mm)	Full

<sup>1</sup> These tracks models feature center hole for third driver.

- Benchmark Challenger lug design
- For boondocking the deepest, bottomless power and climbing the steepest chute
- True 2.5" lug, without notch, to have maximum traction in deep snow

Models  
9174M &  
9175M



MODEL	DIMENSIONS	LUG HEIGHT	WEIGHT	DRIVE PITCH	CLIP CONFIG.
9174M	15" x 153" (38 cm x 389 cm)	2.5" (64 mm)	57 lbs (26 kg)	3" (76 mm)	Full
9175M	15" x 162" (38 cm x 412 cm)	2.5" (64 mm)	55 lbs (25 kg)	3" (76 mm)	Full
9176M	16" x 162" (41 cm x 412 cm)	2.5" (64 mm)	57 lbs (26 kg)	3" (76 mm)	Full

# CHALLENGER 3 NEW

- Full 3" tall lugs provide unmatched traction for boondocking in the most extreme bottomless powder
- Lug geometry and support columns allow lug cup and flex action for unmatched floatation
- Single ply construction, 3" drive pitch and advanced molding technology make it the lightest in its category



MOUNTAIN

MODEL	DIMENSIONS	LUG HEIGHT	WEIGHT	DRIVE PITCH	CLIP CONFIG.
9219M	16" x 162" (41 cm x 412 cm)	3" (76 mm)	61 lbs (28 kg)	3" (76 mm)	Full
9220M	15" x 162" (38 cm x 412 cm)	3" (76 mm)	58 lbs (26 kg)	3" (76 mm)	Full
9270M	15" x 156" (38 cm x 396 cm)	3" (76 mm)	56 lbs (25 kg)	3" (76 mm)	Full
9271M	15" x 174" (38 cm x 442 cm)	3" (76 mm)	63 lbs (29 kg)	3" (76 mm)	Full

# CHALLENGER

- Benchmark Challenger lug design is versatile for all around performance in a wide range of mountain riding conditions
- 2" and 2.313" lugs provide good traction for moderate boondocking and off-trail riding
- Saw-tooth lug feature provides traction and grip on hard, wind-blown and springtime snow

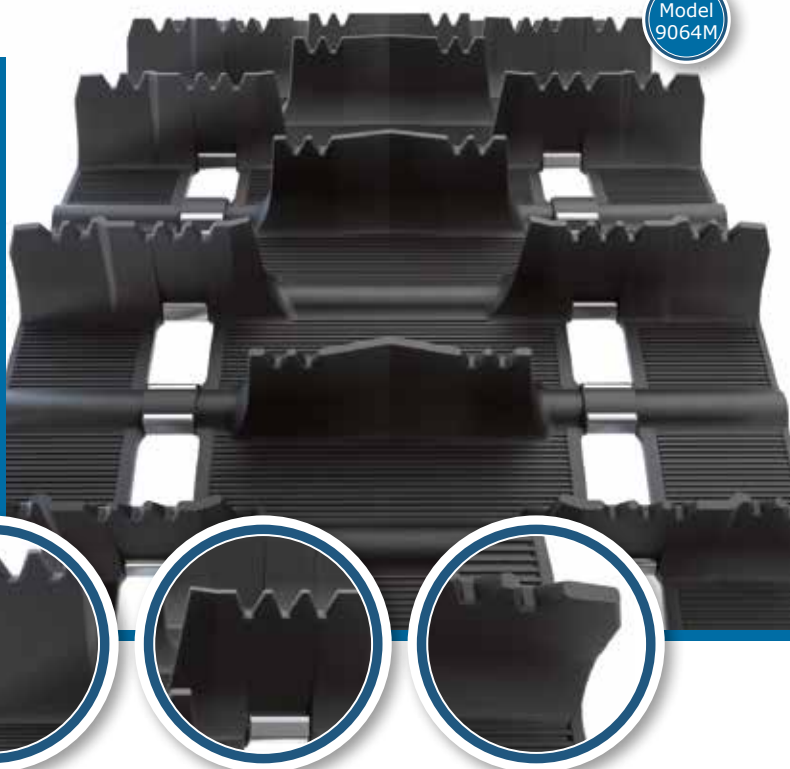

MODEL	DIMENSIONS	LUG HEIGHT	WEIGHT	DRIVE PITCH	CLIP CONFIG.
9064M	16" x 146" (41 cm x 371 cm)	2.313" (59 mm)	49 lbs (22 kg)	2.86" (73 mm)	Full
9065M	16" x 154" (41 cm x 391 cm)	2.313" (59 mm)	53 lbs (24 kg)	2.86" (73 mm)	Full
9186M	16" x 137" (41 cm x 348 cm)	2" (51 mm)	51 lbs (23 kg)	2.86" (73 mm)	Full
9187M	16" x 146" (41 cm x 371 cm)	2" (51 mm)	49 lbs (22 kg)	2.86" (73 mm)	Full
9188M	16" x 154" (41 cm x 391 cm)	2" (51 mm)	57 lbs (26 kg)	2.86" (73 mm)	Full
9204M	16" x 137" (41 cm x 348 cm)	2.313" (59 mm)	46 lbs (21 kg)	2.86" (73 mm)	Full
9797M	15" x 136" (38 cm x 345 cm)	2" (51 mm)	50 lbs (23 kg)	2.52" (64 mm)	Full
9798M	15" x 121" (38 cm x 307 cm)	2" (51 mm)	45 lbs (20 kg)	2.52" (64 mm)	Full
9875M	15" x 144" (38 cm x 366 cm)	2" (51 mm)	51 lbs (23 kg)	2.52" (64 mm)	Full
9876M	15" x 151" (38 cm x 384 cm)	2" (51 mm)	54 lbs (24 kg)	2.52" (64 mm)	Full
9047M	14" x 151" (36 cm x 384 cm)	2.25" (57 mm)	lbs (kg)	2.52" (64 mm)	Full

# PEAK 2.5

2.5" lug height for traction in bottomless powder and high peak climbing

- Angular lugs bite big and funnel snow under the snowmobile for outstanding performance
- Outer lug bars deliver better lateral control for improved handling
- Multi-durometer outside lug configuration for outstanding performance in ALL snow types and conditions



HARD LUGS FOR HEAVY AND WET SNOW TYPES

## Finns ej mera

NEW SOFTER LUGS AT THE TIP AND STIFF BASE FOR POWDER SNOW TYPES

9230M	15" x 154" (38 cm x 392 cm)	2.5" (64 mm)	56 lbs (25 kg)	2.86" (73 mm)	Full
9231M	15" x 163" (38 cm x 414 cm)	2.5" (64 mm)	59 lbs (27 kg)	2.86" (73 mm)	Full
9232M	16" x 154" (41 cm x 392 cm)	2.5" (64 mm)	60 lbs (27 kg)	2.86" (73 mm)	Full
9233M	16" x 163" (41 cm x 414 cm)	2.5" (64 mm)	63 lbs (29 kg)	2.86" (73 mm)	Full

<sup>1</sup> These tracks models feature center hole for third driver.



## Rip Saw drivband

**Deln. 2,52"**



Rip Saw 32 mm			
Nummer	bredd	längd	kam
	cm	cm	mm
04-9922	38	345	32
04-9006	38	365	32
04-9007	38	385	32
04-9925	38	403	32
Special bredd			
04-9021	40,5	345	32



6900-track 31 mm full clip			
Number	width	length	cam
	cm	cm	mm
04-7000	60	397	31
Durasport 25 mm, full clip			
04-9863	38	345	25



Durasport 15 mm full clip			
nummer	bredd	längd	kam
	cm	cm	mm
04-9755	38	290	15
hjul boggie			
04-9756	38	290	15
glig boggie			



Explorer 25 mm Full clip			
Nummer	bredd	längd	kam
	cm	cm	mm
04-9806	38	396	25



Explorer 19 mm full clip			
Nummer	bredd	längd	kam
	cm	cm	mm
04-9011	38	353	19

Camoplast har lagt ned sin finländska snöskoterdrivbandsproduktion. Detta innebär att tillverkningen av de drivband som varit unika för de finska och svenska snöskotrarna, har avslutats. Bl.a. Lynx, Winha, Trapper, Nordik och Ockelbo. En sista tillverkningsomgång av dessa drivband har skett under sommaren 2010.

### Lynx 5900 byte av matta samt förlängning på bakparti.



Kapa av röret

Svetsa ihop med rörbiten  
Rörbitarna levereras med mattan.

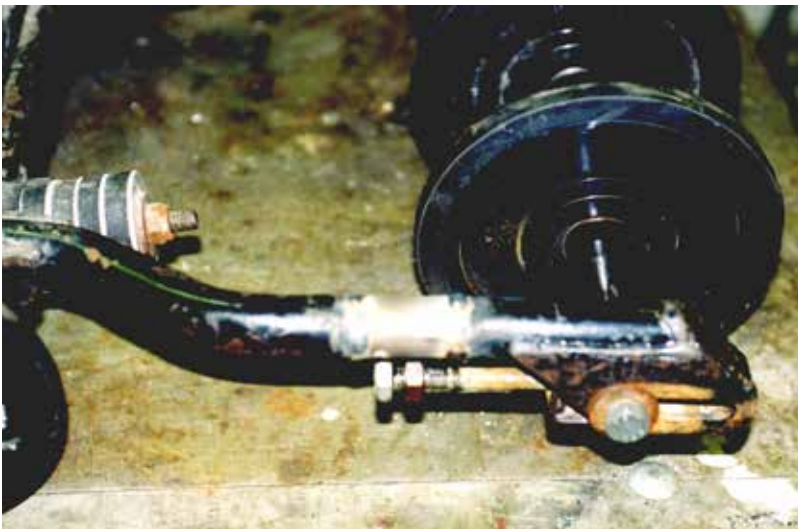

Svetsen har gjorts  
Denna skoter har runda bak hjul. Du kan ersätta även de bakre kugghjulen, om det existerar.

Du måste byta även drivhjulen.  
Det är endast möjligt om det finns en sexkantig drivaxel.

**Vi rekommenderar No Slip hjul**

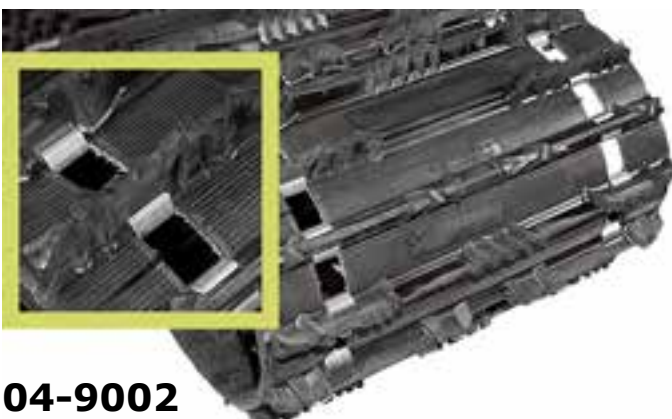

04-9002



Sokosti

04-9005

**(04-9925) + (04-3000) = 403 cm**



**365 cm**



**384 cm**



## Chassiförlängningar i aluminium

### 04-3002

chassie 400-410 mm  
längd 200 mm



### 04-3001

Chassie 400-420 mm  
längd 400 mm



### 04-3003

Chassie 415-430 mm  
längd 400 mm

## Mattskoning

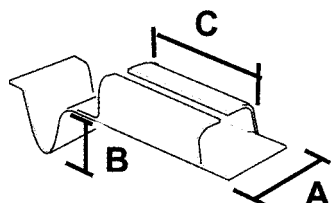

	p/n	A	B	C
	38-02	21	-	30
	38-03	20	16	30
	38-04	23	18	21
	38-05	21	-	38
	38-07	21	-	19
	38-08	22	-	20
	38-09	19	14	25
	38-10	19	-	25

### 38-03

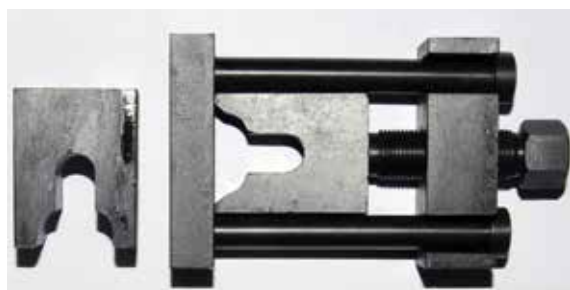

**Verktøy, passar på alla  
Camoplast mattskoningar**

**artikel nummer: 38-100**

## Förlängningssatser

### 04-3050 universal 12 cm

307cm ---> 325cm  
325cm ---> 345cm  
345cm ---> 365cm



25mm axel

### 04-3060 Yamaha 12 cm

307cm ---> 325cm  
325cm ---> 345cm  
345cm ---> 365cm



20mm axel

### 04-3080 Yamaha 20 cm

307cm ---> 345cm  
325cm ---> 365cm



20mm axel

### 04-3300 Lynx 20 cm

320cm ---> 345cm  
330cm ---> 345cm  
**Only LYNX!**

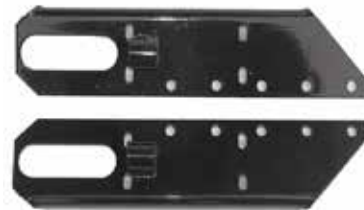

25mm axel

### 04-3040 universal 25 mm axel 20 cm förlängning

307cm ---> 345cm  
325cm ---> 365cm



25mm axel



25mm  
axel

### 04-3070

Förkortningsats. G-type.  
320 cm kan förkortas till  
307cm

### 04-3000 / Flip



**04-3000**

345cm ---> 384cm  
345cm ---> 403cm  
365cm ---> 403cm ++  
**Med flip 30cm längre**



## Flippen

Bilder:

På bilderna ser du en montering av en 384 cm matta.

Montera axeln så långt framåt som möjligt, se bild. Då får du perfekt och tillräcklig justering.



Bilder:

På bilderna ser du montering av en 403 cm matta.

Montera axeln så mycket åt höger (bakåt) i bilden som möjligt, se bild. Då får du perfekt och tillräcklig justering.

